



BR 14p - Type PSA · High-Performance Control and Shut-off Butterfly valve
 DIN- and ANSI-Version



Applications

Tight-closing control and shut-off butterfly valve for use in the pressure swing adsorption process:

- **Nominal size DN 80 to DN 400 and NPS3 to NPS16**
- **Nominal pressure PN 10 to 40 and cl150 / cl300**
- **Temperatures -20°C to +180°C (-4°F to 356°F)**

Pressure swing adsorption (PSA) is a method used to separate a gas from a gas mixture as well as to dry or clean gases.

The purity and quantity of the gas to be extracted strongly depends on the control valves used in this process.

The control valves used in PSA applications must shut-off tightly, have short opening and closing times as well as a high level of operational reliability.

The bidirectional high-performance butterfly valve has the following properties:

- Body in steel (A216 WCB/1.0619) (A352 LCC / 1.6220)
- Body in stainless steel (A351 CF8M/1.4408)
- Lug-type or wafer-type
- Face-to-face dimension in standard version acc. to DIN EN 558 R16 and API 609. Special face-to-face dimensions are available
- Soft seal (PSA Version)
- Operating temperature from -20 to +180 °C (-4°F to +356 °F)
- Gas tight on both sides
- TA-Luft (German clean air act) packing
- Attachment options acc. to DIN ISO 5211

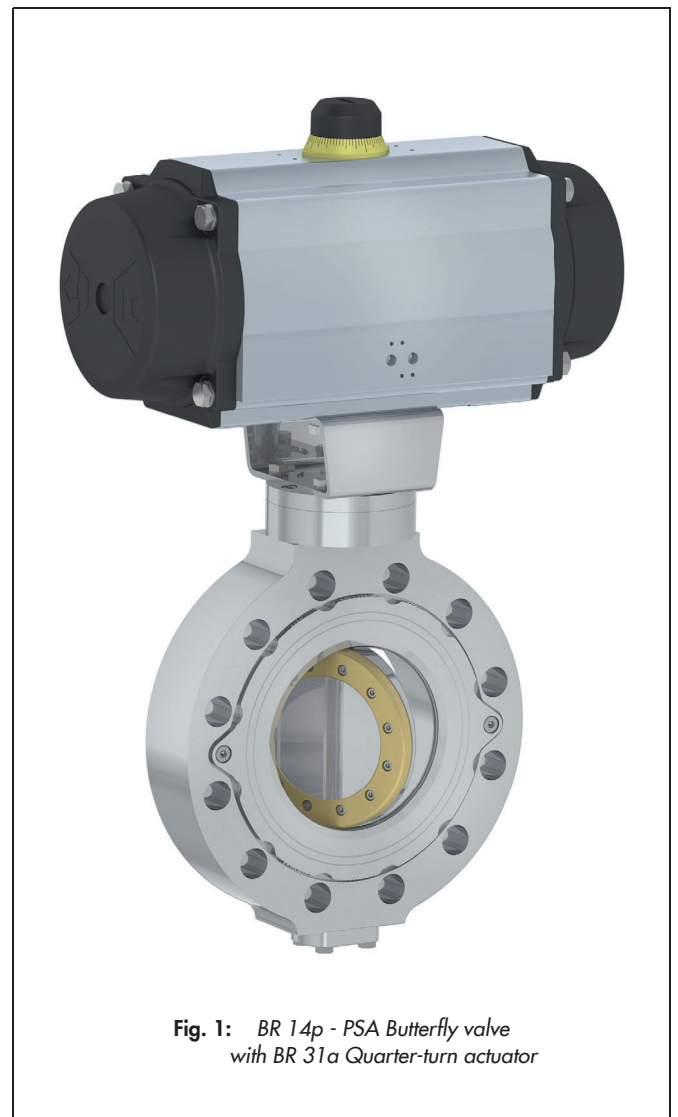

Fig. 1: BR 14p - PSA Butterfly valve with BR 31a Quarter-turn actuator

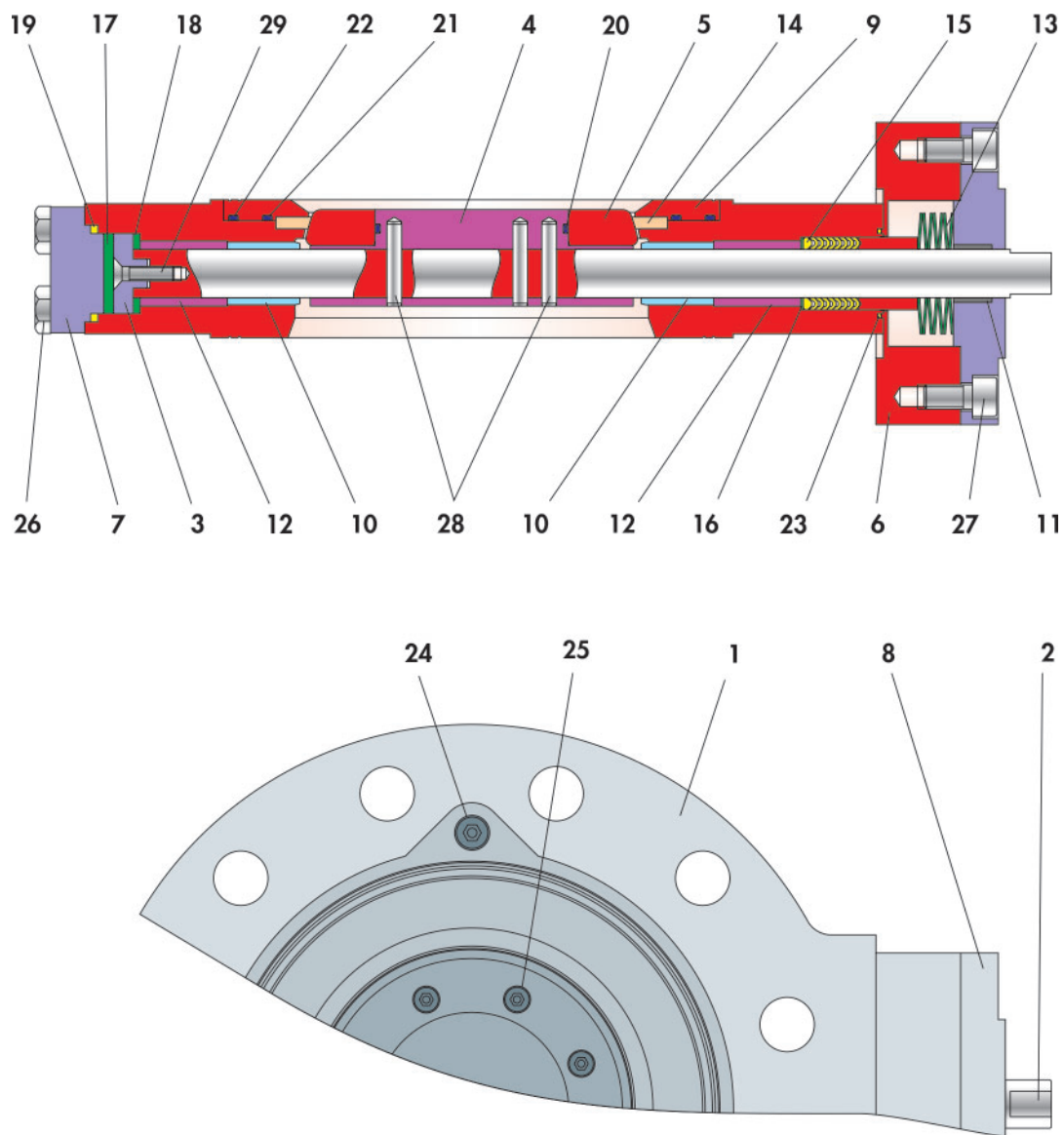

Fig. 2: BR 14p - PSA Butterfly valve

Table 1: Parts list

Item	Description
1	Valve body
2	Valve shaft
3	Shaft head
4	Valve disc
5	Valve disc ring
6	Intermediate flange
7	Bonnet
8	Stuffing box flange
9	Fastening ring
10	Bearing bushing

Item	Description
11	Bearing bushing
12	Spacer
13	Set of spring washers
14	Seat ring
15	V-ring packing
16	Counter washer
17	Mating washer
18	Guide washer
19	PTFE ring
20	O ring

Item	Description
21	O ring
22	O ring
23	PTFE ring
24	Screw
25	Screw
26	Screw
27	Screw
28	Straight pin
29	Screw

Principle of operation

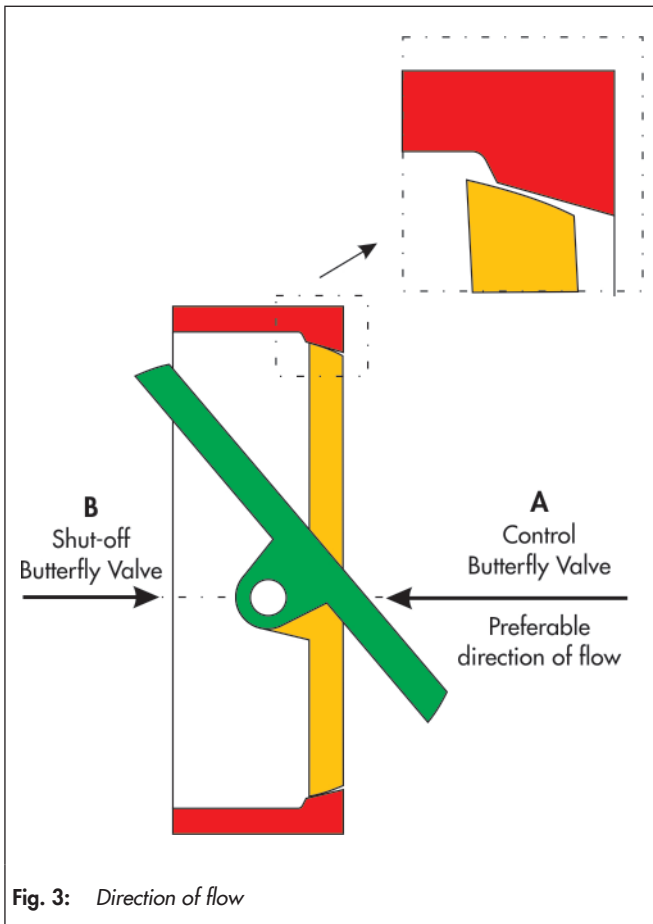

Fig. 3: Direction of flow

The process medium can flow through the valve in both directions.

The disc (4) determines the flow through the free area between disc and seat (15).

Butterfly valves are sealed between the disc (4) and the seat (15).

The shaft (2) is sealed by a packing (16).

The standard packing is a maintenance-free PTFE V-ring packing which is loaded by Belleville spring washers (14).

Optionally, a Graphite/Inconel- packing can be used which is also loaded by Belleville spring washers (14).

The direction of flow and the differential pressure determine the breakaway torque to open the butterfly valve.

The double-eccentric bearing design of the shaft causes the disc on opening and closing to remain in contact with the seat only over a very small angle of rotation (Fig. 5).

This reduces wear and increases the service life of the valve.

In addition, it reduces the breakaway torque.

When the process medium flows through the valve in direction A (Fig. 4), the butterfly disc is slightly pressed out of the seat.

This reduces the pre-load force and the breakaway torque.

When the process medium flows through the valve in direction B, the pre-load force increases as the breakaway torque rises.

Fail-safe position

Depending on how the actuator is mounted, there are two fail-safe positions, which become active when the pressure is relieved and upon failure of air supply:

- **Butterfly valve with fail-close actuator**

Upon failure of the air supply, the butterfly valve closes. The valve opens as the signal pressure increases, opposing the force of the springs.

- **Butterfly valve with fail-open actuator**

Upon failure of the air supply, the butterfly valve opens. The valve closes as the signal pressure increases, opposing the force of the springs.

i Info

These valves are not subject to ATEX 2014/34/EU.

Opening angle

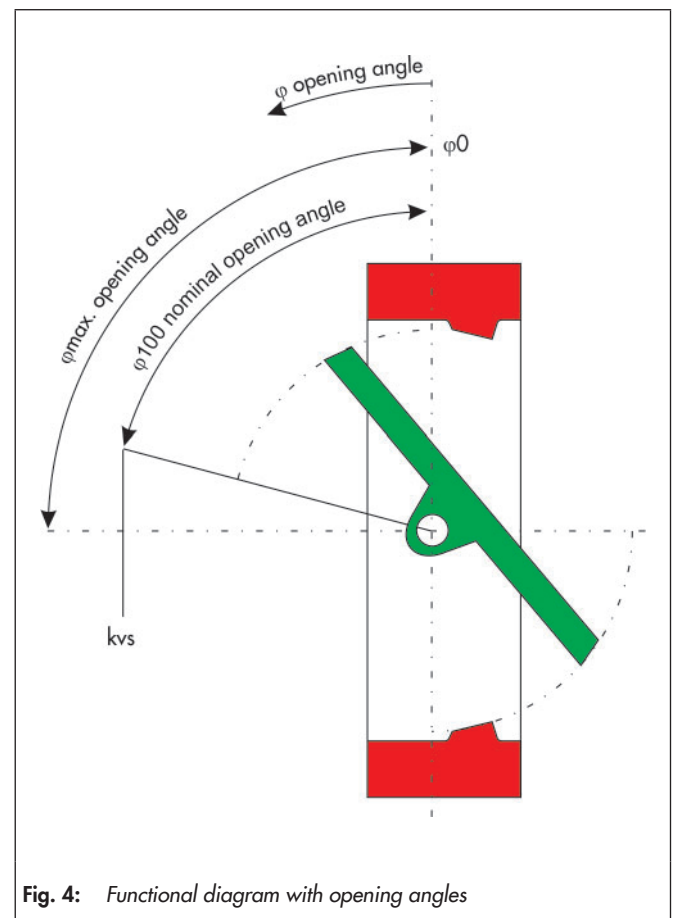

Fig. 4: Functional diagram with opening angles

Table 2: *Technical data*

Nominal size	DN 80 to DN 400 and NPS3 to NPS16	
Nominal pressure	PN 10 to PN 40 and ANSI cl150 / cl300	
Body style	Lug-Type or Wafer-Type	
Seat ring	Soft seal (PSA version)	
Leakage rate	Leckrate A acc. to DIN EN 12266-1, P12	Leakage rate VI acc. to ANSI / FCI 70-2-2006
Rangeability	50 : 1	
Face to face dimensions	DIN	DIN EN 558, Series 16
	ANSI	API cl150 / API cl300

Table 3: *Material*

	Steel	Stainless steel
Valve body	1.0619 (A216 WCB)	1.4408 (A351 CF8M)
Valve disc and disc ring	1.0619 (A216 WCB)	1.4408 (A351 CF8M)
Valve shaft and shaft head	1.4542 (AISI 630) / 1.4542-H1150 (A564 Type 630 P930)	
Seat ring	Soft seal (PSA version)	
Fastening ring	1.4571 (A479 F316Ti)	
Stuffing box flange	1.4571 (A479 F316Ti)	
Packing	PTFE V-ring packing, spring loaded	

Table 4: *Terms for noise level calculation*

φ	10°	20°	30°	40°	50°	60°	70°	80°	90°
z	0.35	0.30	0.25	0.20	0.17	0.14	0.12	0.11	0.10

z values for noise level calculation acc. to VDMA 24422 and terms for control valve sizing acc. to DIN EN 60534.

Correction terms

- With gases and vapors $\Delta LG = 0$
- With liquids $\Delta LF = 0$

Table 5: *Valve sizing terms*

Pressure range	φ	10°	20°	30°	40°	50°	60°	70°	80°	90°
PN 10 / 16 ANSI cl150	FL	0.83	0.81	0.80	0.79	0.74	0.69	0.61	0.56	0.53
	XT	0.51	0.50	0.49	0.47	0.42	0.36	0.31	0.26	0.25
PN 25 / 40 ANSI cl300	FL	0.82	0.80	0.80	0.78	0.74	0.65	0.54	0.49	0.45
	XT	0.51	0.50	0.49	0.46	0.39	0.31	0.25	0.22	0.20

Table 6: Torque and breakaway torques

Nominal size		Perm. torques M _{dmax.} in Nm with shaft in		Soft-seated butterfly disk Breakaway torque M _{dI} in Nm with differential pressure Δp in bar				
				1.4542	1.4542 / H1150	0	10	16
DN 80	NPS3	493	316	30	35	46	55	70
DN 100	NPS4	493	316	30	35	46	55	70
DN 150	NPS6	1040	749	40	50	72	90	120
DN 200	NPS8	2031	1463	40	55	112	153	220
DN 250	NPS10	3510	2527	80	140	268	374	550
DN 300	NPS12	5574	4013	200	315	390	495	670
DN 350	NPS14	8320	5990	300	535	680	895	1250
DN 400	NPS16	11846	8529	350	600	750	975	1350

The breakaway torques specified are average values which were measured with air at 20°C with the corresponding differential pressure. Operating temperature, process medium and long operating times may affect the permissible torques and breakaway torques considerably.

Characteristic curve

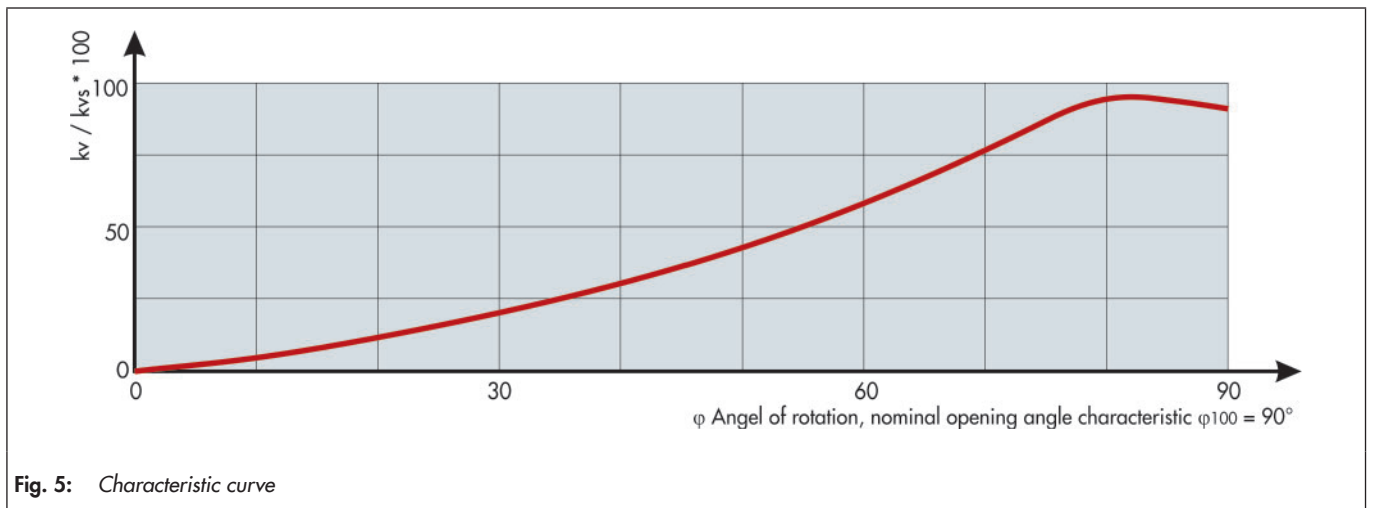

Fig. 5: Characteristic curve

Table 7: KV and CV coefficients and related opening angles

Pressure rating PN	DN	NPS	Opening angle ϕ																	
			10°		20°		30°		40°		50°		60°		70°		80°		90°	
			k _v	C _v	k _v	C _v	k _v	C _v	k _v	C _v	k _v	C _v	k _v	C _v	k _v	C _v	k _v	C _v	k _v	C _v
PN 10 - 40 ANSI cl150 / cl300	80	3	5	6	9	11	16	19	27	32	45	53	68	79	98	117	126	147	143	167
	100	4	9	11	23	27	44	51	67	78	98	114	145	168	189	219	248	289	282	329
	150	6	23	27	77	89	147	171	224	260	326	378	485	563	634	735	722	838	772	901
	200	8	48	56	149	173	285	331	435	505	633	734	941	1092	1231	1428	1404	1638	1596	1863
	250	10	85	99	258	299	398	462	682	791	995	1154	1495	1734	1974	2290	2449	2841	2589	3021
	300	12	124	144	377	437	582	675	998	1158	1456	1689	2188	2538	2890	3352	3585	4166	4056	4733
	350	14	163	189	495	574	764	886	1310	1520	1910	2216	2870	3329	3790	4396	4737	5528	5383	6282
	400	16	222	258	674	782	1040	1206	1783	2068	2601	3017	3908	4533	5160	5986	6401	7425	7111	8298

Dimensions and weights

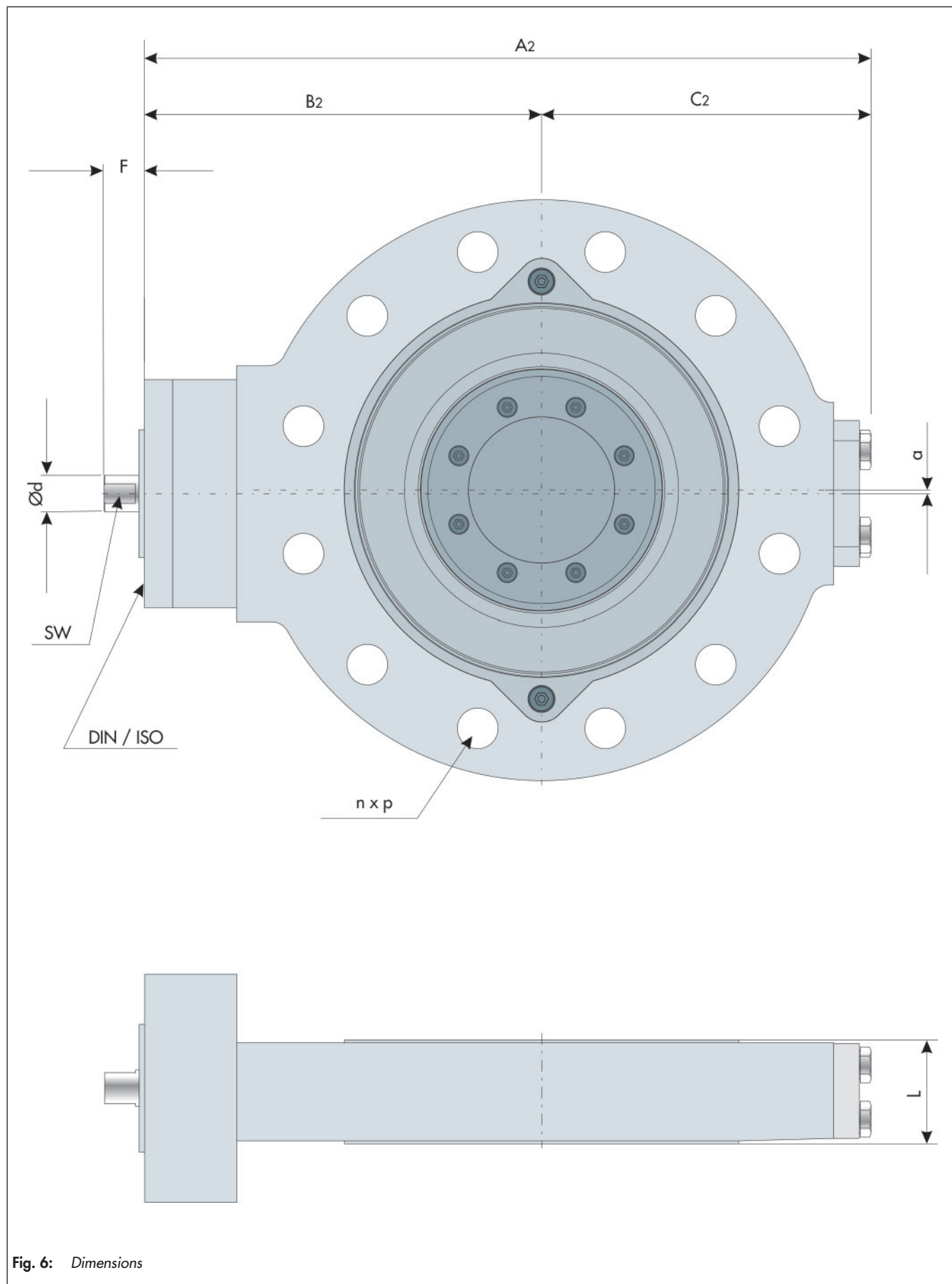

Fig. 6: Dimensions

Table 8: Dimensions in mm and Weights in kg

Nominal size		DN 80	DN 100	DN 150	DN 200	DN 250	DN 300	DN 350	DN 400
		NPS3	NPS4	NPS6	NPS8	NPS10	NPS12	NPS14	NPS16
L	PN 10 to 40	64	64	76	89	114	114	127	140
	Optionally PN 10 to 25	48	54	57	64	71	81	92	102
	ANSI cl150	48	54	57	64	71	81	92	102
	ANSI cl300	48	54	59	73	83	92	117	133
A1		232	274.3	346.3	408.4	491	564.5	658	713.5
B1		112	132	167	197	237	271	326	351
C1		120	142.3	179.3	211.4	254	293.5	332	362.5
A2		277	319.3	398	458	529.5	643.5	741.5	788
B2		157	177	217.5	246.5	275.5	350	409.5	425.5
C2		120	142.3	180.5	211.5	254	293.5	332	362.5
a		1	1.5	2	3	4	5	6	6
SW		11	11	14	19	24	24	30	30
DIN / ISO		F07	F07	F10	F12	F12	F16	F16	F16
ØD Lug- Type	PN 10	200	235	300	340	405	460	520	580
	PN 16	200	235	300	340	405	460	520	580
	PN 25	200	235	300	375	450	515	580	660
	PN 40	200	235	300	375	450	515	580	660
	ANSI cl150	210	230	280	343	406	483	534	597
	ANSI cl300	210	254	318	381	445	521	584	648
ØD Wafer- Type	PN 10	200	235	300	340	405	460	520	580
	PN 16	200	235	300	340	405	460	520	580
	PN 25	200	235	300	375	450	515	580	660
	PN 40	200	235	300	375	450	515	580	660
	ANSI cl150	210	230	280	343	406	483	534	597
	ANSI cl300	210	254	318	381	445	521	584	648
ØK	PN 10	160	180	240	295	350	400	460	515
	PN 16	160	180	240	295	355	410	470	525
	PN 25	160	190	250	310	370	430	490	550
	PN 40	160	190	250	320	385	450	510	585
	ANSI cl150	152.4	190.5	241.3	298.5	362	431.8	476.3	539.8
	ANSI cl300	168.1	200.2	269.7	330.2	387.4	450.9	514.4	571.5
n x P Lug- Type	PN 10	8 x M16	8 x M16	8 x M20	8 x M20	12 x M20	12 x M20	16 x M20	16 x M24
	PN 16	8 x M16	8 x M16	8 x M20	12 x M20	12 x M24	12 x M24	16 x M24	16 x M27
	PN 25	8 x M16	8 x M20	8 x M24	12 x M24	12 x M27	16 x M27	16 x M30	16 x M33
	PN 40	8 x M16	8 x M20	8 x M24	12 x M27	12 x M30	16 x M30	16 x M33	16 x M36
	ANSI cl150	4 x 5/8"	8 x 5/8"	8 x 3/4"	8 x 3/4"	12 x 7/8"	12 x 7/8"	12 x 1"	16 x 1"
	ANSI cl300	8 x 3/4"	8 x 3/4"	12 x 3/4"	12 x 7/8"	16 x 1"	16 x 11/8"	20 x 11/8"	20 x 11/4"
n x ØP Wafer- Type	PN 10	8 x 18	8 x 18	8 x 22	8 x 22	12 x 22	12 x 22	16 x 22	16 x 26
	PN 16	8 x 18	8 x 18	8 x 22	12 x 22	12 x 26	12 x 26	16 x 26	16 x 30
	PN 25	8 x 18	8 x 22	8 x 26	12 x 26	12 x 30	16 x 30	16 x 33	16 x 36
	PN 40	8 x 18	8 x 22	8 x 26	12 x 30	12 x 33	16 x 33	16 x 36	16 x 39
	ANSI cl150	4 x 19.1	8 x 19.1	8 x 22.4	8 x 22.4	12 x 25.4	12 x 25.4	12 x 28.4	16 x 28.4
	ANSI cl300	8 x 22.4	8 x 22.4	12 x 22.4	12 x 25.4	16 x 28.4	16 x 31.8	20 x 31.8	20 x 35.1
Ød		15	15	20	25	30	35	40	45
Gewicht in kg		19	23	41	67	100.5	163	229	277

Selecting and sizing the butterfly valve

1. Calculate the appropriate KV coefficient.
2. Select the nominal size and KVS coefficient from Table 6.
3. Check the operation conditions taking the pressure-temperature diagram into account.
4. Select a suitable actuator.

Ordering text:

High-Performance Butterfly Valve BR 14p - PSA	
Nominal size	DN
Nominal pressure	PN
Valve body material	Acc. to Table 2
Seat seal	Metal seal or soft seal
Direction of flow	"A" standard direction of flow for throttling service "B" reversed direction of flow for shut-off service
Manual gear or actuator	Brand name:
Fail-safe position	Valve "OPEN" or valve "CLOSED"
Supply air bar
Operating range	Number of springs
Operating pressure bar
Medium temperature °C or °F
Medium	Dry or lubricating
Limit switch	Brand name:
Solenoid valve	Brand name:
Positioner	Brand name:
Others

Associated Data Sheets

- For Multi-turn act BR 30a, vgl. ▶ TB 30a.
- For Quarter-turn actuator BR 31a, vgl. ▶ TB 31a.

Info

All relevant details regarding the version ordered, which deviate from the specified version in this data sheet can be taken if required, from the corresponding order confirmation.
