



BR 20b · PFA-lined Ball Valve DIN and ANSI Version



Applications

Tight-closing PFA-lined ball valve for (highly) corrosive media, especially with high process demands in chemical plants:

- **Nominal size DN 15 to DN 200 and NPS½ to NPS3**
- **Nominal pressure PN 16 and cl150**
- **Temperature range -10°C to +200°C (14°F to 392°F)**

The controlling device consists of a PFA-lined ball valve with a pneumatic quarter-turn actuator, a manual gear or a lever.

The valves are designed according to the modular-assembly principle have the following features

- Full bore, high KV values
- Body of EN-JS 1049 (0.7043 / A395) with PFA-liner (min. 3 mm wall thickness)
- Exchangeable PTFE seat rings
- 1 pcs ball/stem of stainless steel (1.4313) with PFA liner (min. 3 mm wall thickness)
- Hysteresis free, perfect for throttling service
- Shaft sealed by a self-adjusting PTFE V-ring packing, supported by disc springs, maintenance-free
- Blowout-proof shaft
- Connecting flange for actuators acc. to DIN ISO 5211
- DIN version with face-to-face dimensions acc. to DIN EN 558
- ANSI version with face-to-face dimensions acc. to ASME B16.10
- High-quality 2-component PU coating (RAL 1019) as protection against corrosive atmosphere and corrosive formation

Versions

BR 20b ball valve are optionally available in the following versions:

- Ball valve with lever (DN 15 to 100 or NPS½ to 3)
- Ball valve with manual gear
- Ball valve with pneumatic quarter-turn actuator (see associated data sheet for details)
- Acc. to customer specifications

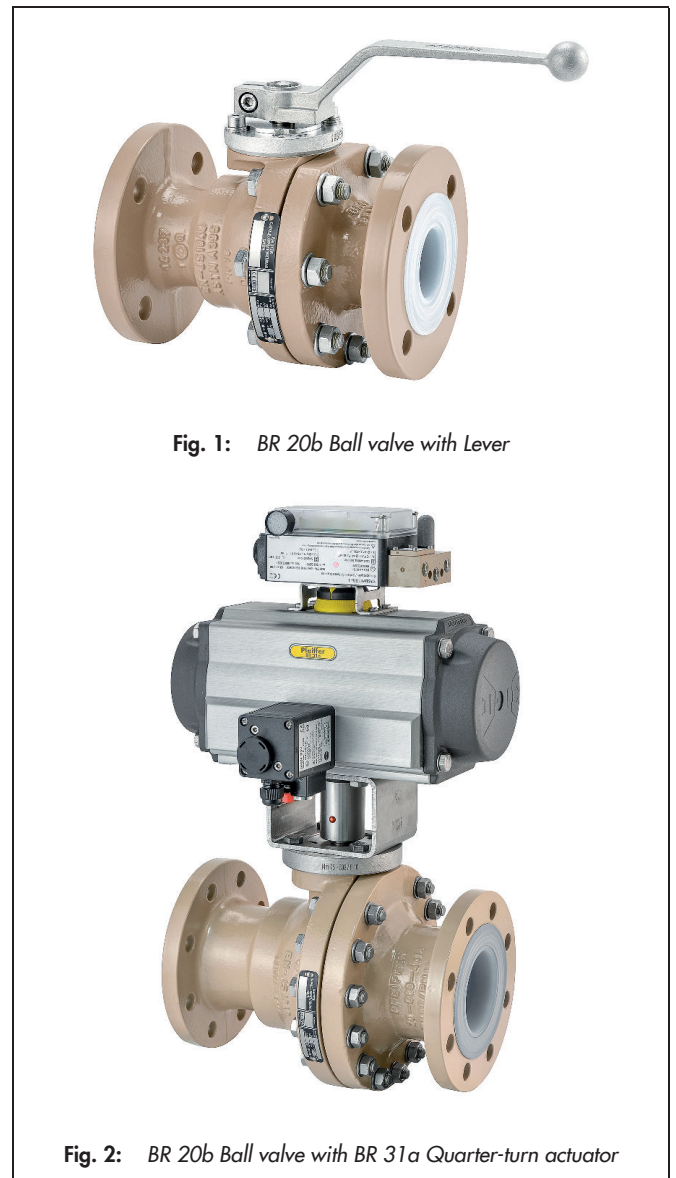

Fig. 1: BR 20b Ball valve with Lever

Fig. 2: BR 20b Ball valve with BR 31a Quarter-turn actuator

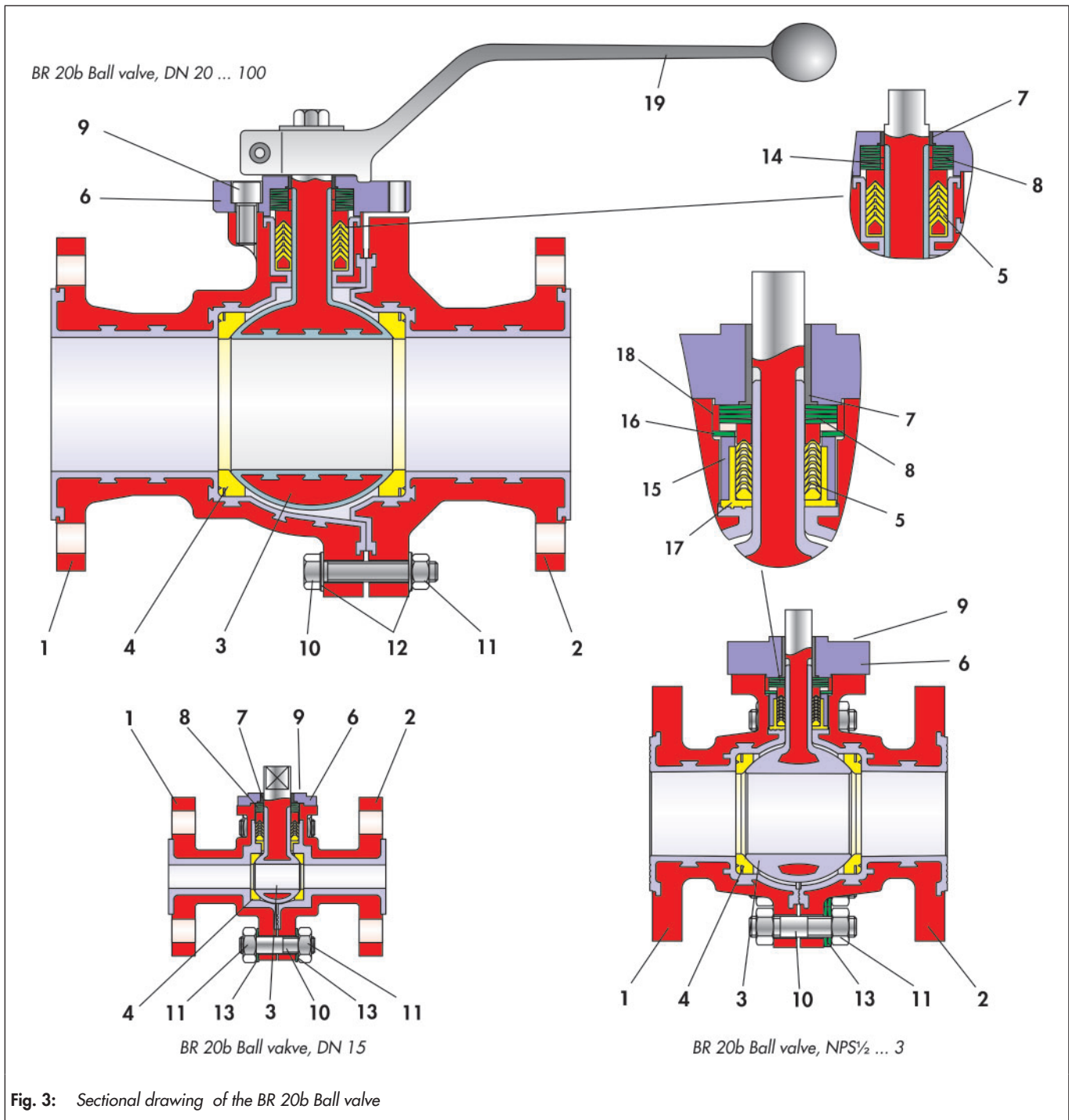

Fig. 3: Sectional drawing of the BR 20b Ball valve

Table 1: List of parts

Item	Description
1	Main body with lining
2	Body with lining
3	Ball with coating
4	Seat ring
5	V-ring packing
6	Gland flange
7	Bearing bush
8	Disc spring set
9	Screw
10	Screw / Stud bolt

Item	Description
11	Nut
12	Washer
13	Disc spring
14	Bush
15	Bush
16	Disc spring
17	Bush
18	Center ring
19	Lever

Special versions

- Valve body made of stainless steel 1.4571
- Ball valve for controlling by characteristic seat ring
- Variety of material for ball and seat ring
- Lining PFA - conductive
- Heating jacket, stainless steel
- FDA conform sealing materials
- Ball / Shaft two-piece
- According to customer specifications

Principle of operation

The BR 20b Ball valves allow full flow through the valve in either directions.

The ball (3) with its cylindrical passage slew around the middle axis.

The opening angle of the ball determines the flow through the free area between the body (1) and bore.

When the ball valve is opened, the entire profile is available.

The ball (3) is sealed by exchangeable seat rings (4).

The ball shaft is sealed by a PTFE V-ring packing (5) which is spring supported by disc springs (8) positioned above the packing.

The shaft is equipped with a lever. Optionally, a pneumatic actuator or gear-operated actuator can be assembled.

Fail-safe position

Depending on assembly position of the pneumatic actuator, the valve has two fail-safe positions which become effective when the air pressure in the actuator is relieved or when the supply air fails:

- **Ball valve with fail-close actuator:**
While air failure, the valve is closed. The valve opens when the signal pressure increases, acting against the force of the springs.
- **Ball valve with fail-open actuator**
While air failure, the valve opens. The valve closes when the signal pressure increases, acting against the force of the springs.

i Note

The ball valve can also be used for control applications. Refer to the data sheet ► DB 20a-kd.

i Note

Before using the valve in hazardous areas, check whether this is possible acc. to ATEX 2014/34/EU by referring to the operating instructions ► BA 20a.

Optional material combinations

For best adaption to process conditions, it is possible to optimize ball valve by modification of materials (eg. body, shaft, ball and sealing).

Additional accessories

The following accessories are available (separately or in combination):

- Locking device
 - Shaft extension (100 mm, standard)
 - Pneumatic or electric quarter-turn actuators
 - Positioner
 - Limit switches
 - Solenoid valves
 - Filter regulator
 - Heating jacket available for various nominal sizes on request (not for ANSI versions)
 - Ball valve for control application by characteristic seat ring
- Further accessories are possible on customer request.

Advantages of the live-loaded sealing system

- Maintenance-free and self-adjusting
- Highest tightness, even under extreme pressure and temperature conditions
- High durability

All in all: Extremely economic!

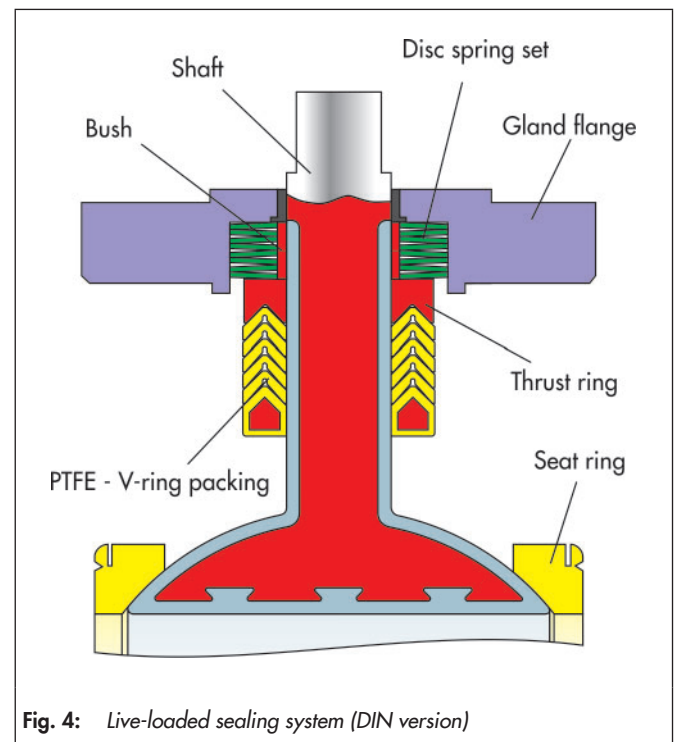

Fig. 4: Live-loaded sealing system (DIN version)

Pressure-temperature diagram

The operating range is given by the pressure-temperature diagram. Process data and medium may influence the values in the diagram.

Pressure-temperature diagram, PN 16

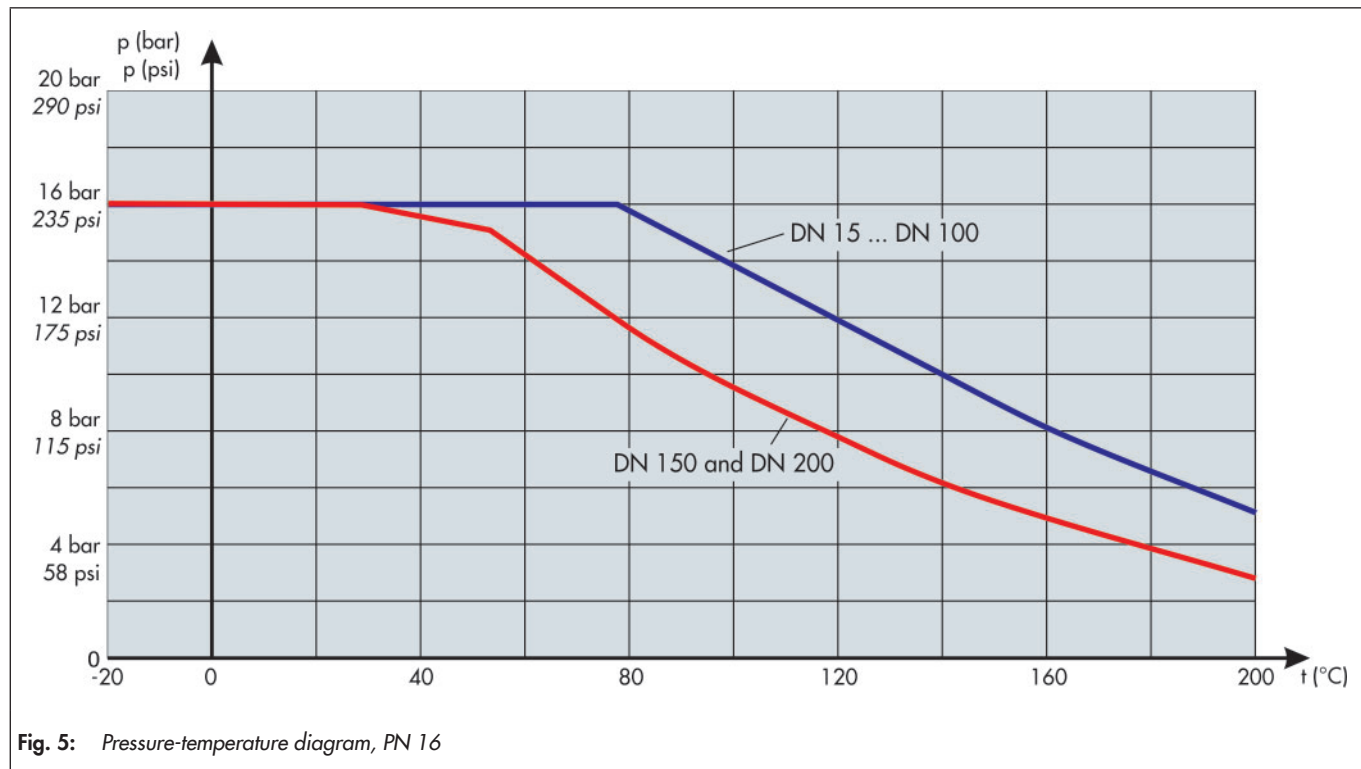

Fig. 5: Pressure-temperature diagram, PN 16

Pressure-temperature diagram, c1150

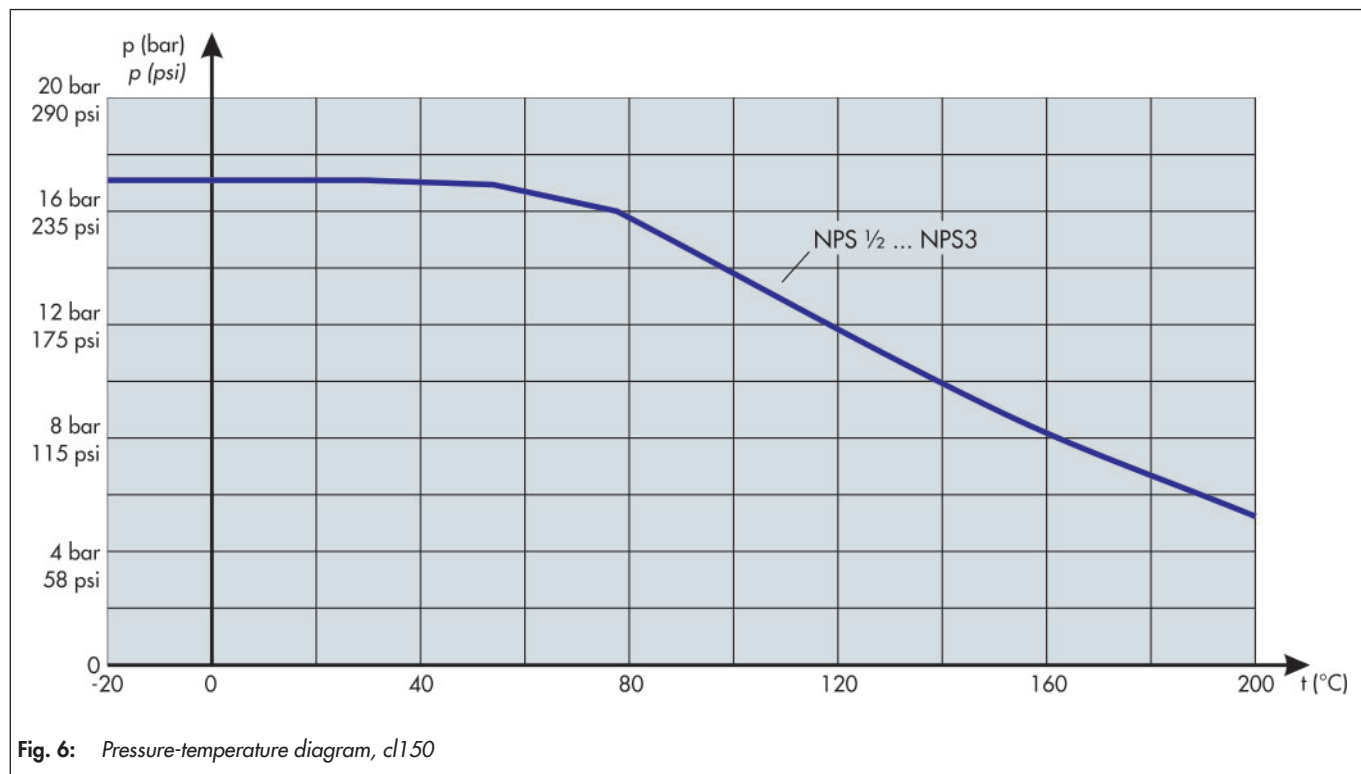

Fig. 6: Pressure-temperature diagram, c1150

Table 2: General technical data

	DIN	ANSI
Nominal size	DN 15 ... 200	NPS½ ... 3
Nominal pressure	PN 16	d150
Temperature range	-10 ... 200°C (optionally -40 °C)	
Leakage rate	Leakage rate A acc. to DIN EN 12266-1, P12 (leakage rate 1 BO acc. to DIN 3230 Part 3)	
Flanges	Acc. to DIN EN 1092-2, Form B	ASME B16.5
Packing	PTFE V-ring packing supported by disc springs	
Face-to-face dimensions	DIN EN 558 row 1, DN 15 ... DN 150 DIN EN 558 row 12, DN 200	ASME B16.10 Short Pattern A, NPS½ ... NPS 4 ASME B16.10 Short Pattern B, NPS8

Table 3: Materials

	DIN	ANSI
Body	EN-JS 1049 / 0.7043 with PFA-lining (min. 3mm)	A395 with PFA-lining (min. 3mm)
Ball / Shaft	1.4313 with PFA-casing (min. 3mm)	
Seat rings	Virgin PTFE	
Packing	PTFE - V-ring-packing	
Disc spring set	1.8159, Delta Tone	
Bearing bush	PTFE with 25 % carbon	
Body sealing	PFA	
Paint coating	Two-component polyurethane, grey beige, RAL 1019	

Table 4: kvs and Cv coefficients

DN	15	25	40	50	80	100	150	200
NPS	½	1	1½	2	3	-	-	-
kvs	10	45	105	163	402	587	1554	2670
Cv	12	52	122	190	467	682	1810	3111

Table 5: Operating and breakaway torques

Differential pressure		Δp in bar		0	5	10	16
DN	NPS	Perm. operating torque MDmax. in Nm	Req. operating torque Md in Nm	Breakaway torque Mdl in Nm			
15	½	126	6	10	10	10	16
25	1	140	6	10	12	14	17
40	1½	140	12	20	22	24	29
50	2	140	17	30	32	34	39
80	3	608	44	74	80	86	101
100	-	833	70	120	128	136	154
150	-	1570	210	300	380	450	540
200	-	6515	270	380	430	505	570

The above listed torques are based on the opening of the ball valve at the differential pressure for water with corrosion inhibitors added at room temperature and with one-day non-actuation.

Since temperature, pressure, process medium, switching frequencies and idle times considerably affect the arising torques, corresponding factors need to be taken into consideration on selecting and sizing the actuator. In case of doubt, contact Pfeiffer. The listed maximum permissible torques apply to the standard material listed in Table 3.

Dimensions and weights

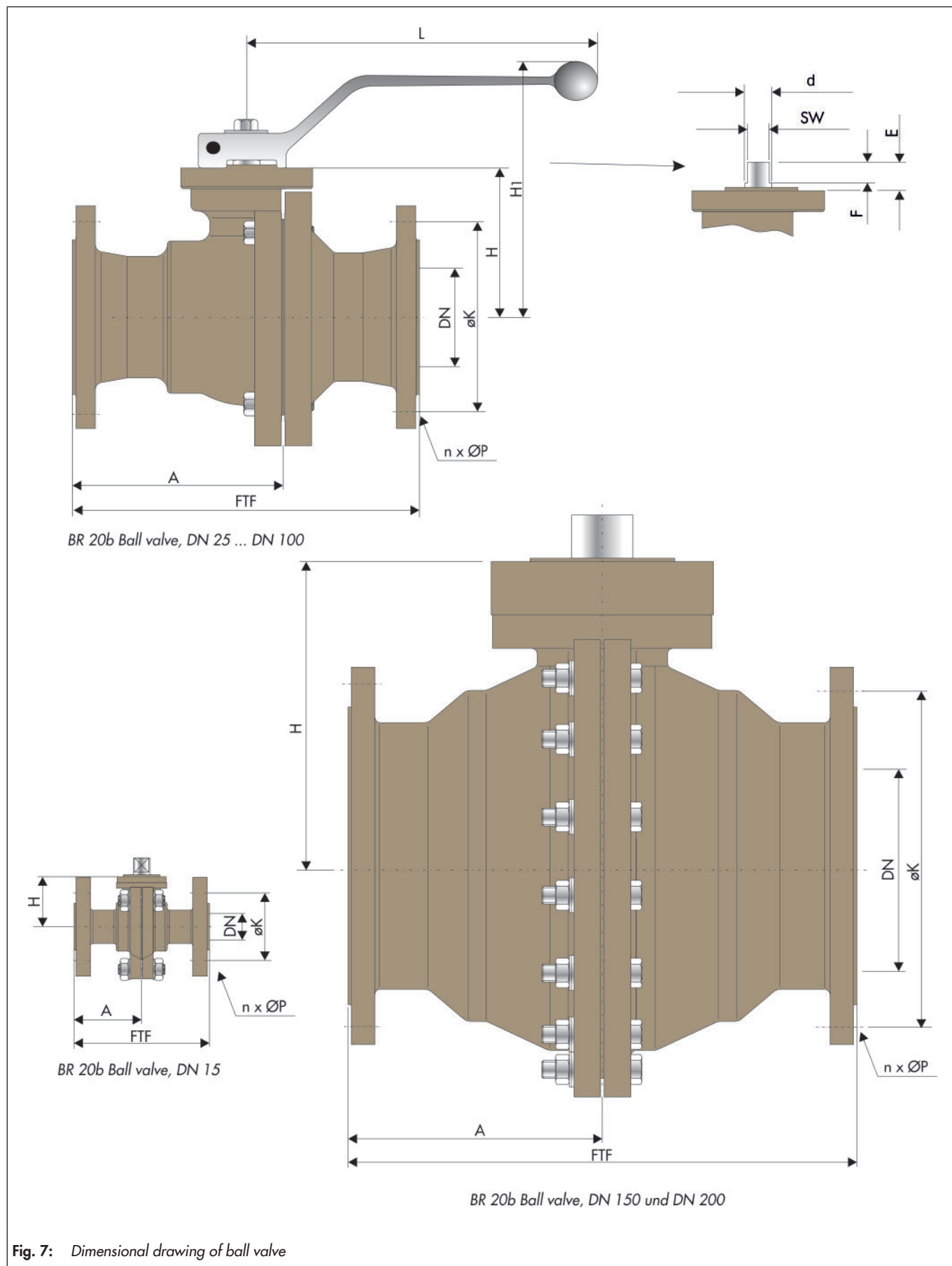

Table 6: Dimensions in mm and weights in kg of the DIN Ball valve

DN	15	25	40	50	80	100	150	200
FTF	130	160	200	230	310	350	480	457
A	65	80	100	115	155	175	240	228.5
H	48	76	85	90	133.5	152	210.5	265
H1	115	142	159	164	200	221	-	-
E	18	19	19	19	23	27	25	42
F	12	12	12	12	16	20	18	34
L	152	152	220	220	365	365	-	-
SW	12	12	12	12	16	20	24	34
Ø d	16	16	16	16	24	28	36	55
DIN ISO Connection	F05	F05	F07	F07	F10	F12	F14	F16
ØK	65	85	110	125	160	180	240	295
nxØP	4x14	4x14	4x18	4x18	8x18	8x18	8x22	8x22
Weight in kg	5	7	12	14	29	37	85	156

Table 7: Dimensions in mm and weights in kg of the ANSI Ball valve

NPS	½	1	1½	2	3
FTF	108	127	165	178	203
A	54	63.5	82.5	89	101.5
H	48	76	96	103	135.5
H1	116	145	165	166	208
E	18	19	19	19	21
F	12	12	12	12	16
L	155	155	155	220	370
SW	12	12	12	12	16
Ø d	16	16	16	16	24
DIN ISO Connection	F05	F05	F05	F05	F07
ØK	60.3	79.4	98.4	120.7	152.4
nxØP	4x ⁵ / ₈ "	4x ⁵ / ₈ "	4x ⁵ / ₈ "	4x ³ / ₄ "	4x ³ / ₄ "
Weight in kg	4.5	5.5	9.5	11	18

Selection and sizing of the ball valve

1. Determine the required nominal size
2. Select valve in accordance with table 2 and 3 and by pressure-temperature diagram
3. Select the appropriate actuator using table 5
4. Select additional equipment

Order text

BR 20b PFA ball valve

DN

PN

optional special version

Lever, resp. actuator (brand name):

Supply pressure: bar

Fail-safe position:

Limit switch (brand name):

Solenoid valve (brand name):

Positioner:

Other:

Associated Data Sheets

- For Multi-turn actuators ▶ TB 30a
- For Quarter-turn actuators ▶ TB 31a

Note

All relevant details regarding the version ordered, which deviate from the specified version in this technical description data, can be taken from the order confirmation.
