

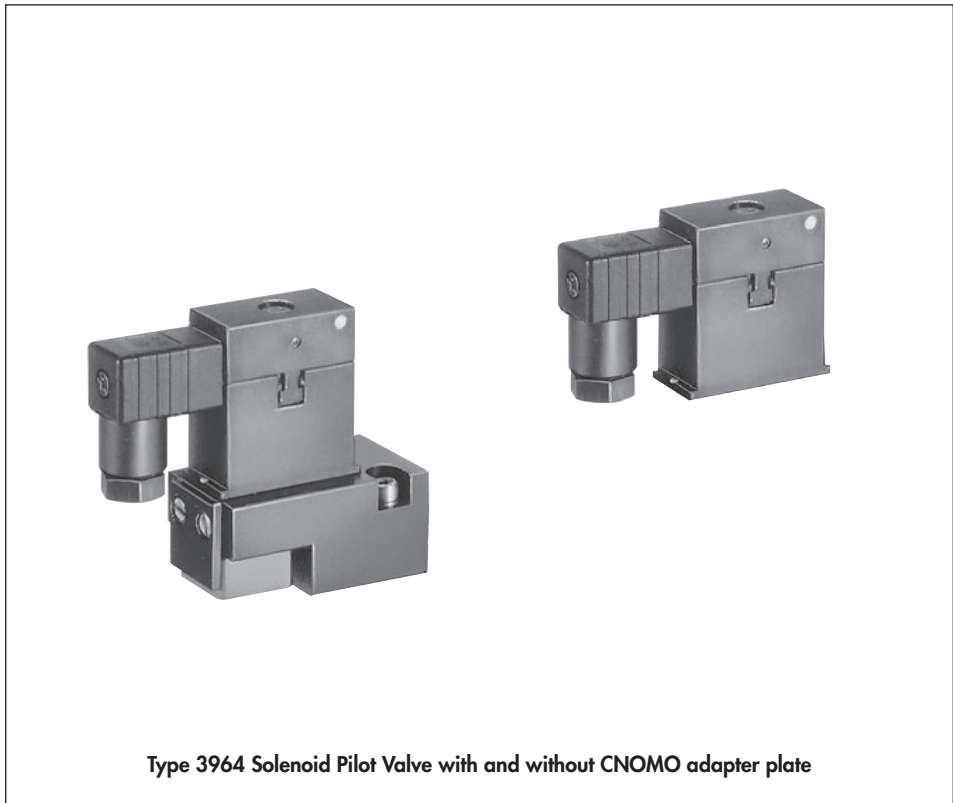

SH 3964 EN

Translation of original instructions



Type 3964 Solenoid Pilot Valve with and without CNOMO adapter plate

Type 3964 Solenoid Pilot Valve

Definition of signal words

DANGER

Hazardous situations which, if not avoided, will result in death or serious injury

WARNING

Hazardous situations which, if not avoided, could result in death or serious injury

NOTICE

Property damage message or malfunction

Note

Additional information

Tip

Recommended action

Purpose of this manual

The Safety Manual SH 3964 contains information relevant for the use of the Type 3964 Solenoid Pilot Valve in safety-instrumented systems according to IEC 61508 and IEC 61511. The safety manual is intended for planners, constructors and operators of safety-instrumented systems.

NOTICE

Risk of malfunction due to incorrect mounting, connection or start-up of the solenoid pilot valve.

Refer to the Mounting and Operating Instructions EB 3964 on how to mount the device, perform the electric and pneumatic connections as well as start up the device.

→ *Observe the warnings and safety instructions written in the Mounting and Operating Instructions EB 3964.*

Further documentation

The documents listed below contain descriptions of the start-up, functioning and operation of the limit switch. You can download these documents from the SAMSON website.

- ▶ T 3964: Data sheet
 - ▶ EB 3964: Mounting and operating instructions
-

Note

In addition to the solenoid pilot valve documentation, observe the technical documentation for the pneumatic actuator, control valve and other valve accessories.

Contents

1	Scope	5
1.1	General	5
1.2	Use in safety-instrumented systems	5
1.3	Versions and ordering data	5
2	Mounting	7
3	Technical data	7
4	Safety-related functions	9
4.1	Fail-safe action	10
4.2	Protection against unauthorized changes to the configuration	10
5	Mounting, connection and start-up	10
6	Required conditions	10
6.1	Selection	10
6.2	Mechanical and pneumatic installation	11
6.3	Electrical installation.....	11
7	Proof testing.....	12
7.1	Visual inspection to avoid systematic failure	12
7.2	Function testing.....	13
8	Maintenance and repair	14
9	Safety-related data and certificates	14

1 Scope

1.1 General

The Type 3964 Solenoid Pilot Valve can be used to actuate SAMSON Type 3756 Booster Valves, SAMSON Type 3965 and 3968 Solenoid Valve Islands as well as valves according to ISO 5599-1 with CNOMO interface.

1.2 Use in safety-instrumented systems

Observing the requirements of IEC 61508, the systematic capability of the solenoid valve, which is integrated into the pilot valve, for emergency venting as a component in safety-instrumented systems is given.

On observing the requirements of IEC 61511 and the required hardware fault tolerance, the solenoid pilot valve is suitable for use in safety-instrumented systems up to SIL 2 (HFT = 0). On observing the minimum required fault tolerance of HFT = 1, the solenoid pilot valve can be used in a redundant version also up to SIL 3.

The solenoid pilot valve is regarded as a type A device according to IEC 61508-2 in view of its safety functions.

1.3 Versions and ordering data

Not all versions of the Type 3964 Solenoid Pilot Valve are suitable for use in safety-instrumented systems. Solenoid pilot valves suitable for safety-instrumented systems are recognizable by their article code (see ordering data); they have "1" in the 12th place after the hyphen "-" (3964-xxxxxxxxxx1):

Solenoid pilot valve	Type 3964-	x	x	x	x	x	x	x	x	x	x	x	x
Type of protection													
No explosion protection		0											
II 2 G Ex ia IIC T6 (ATEX) ¹⁾ , zone 1		1											
Ex ia IIC (CSA) and AEx ia IIC (FM)		3											
II 3 G Ex nA II T6 (ATEX) ²⁾ , zone 2		8											
Nominal signal													
6 V DC, 5.47 mW power consumption		1											
12 V DC, 13.05 mW power consumption		2											
24 V DC, 26.71 mW power consumption		3											

Scope

Solenoid pilot valve	Type 3964- x x x x x x x x x x x x												
Manual override													
Without manual override (SIL)	0												
Pushbutton	1												
Pushbutton/switch	2												
Mounting													
Interface for direct mounting of Type 3964	0												
CNOMO adapter plate, 30 mm	1												
K _{VS} coefficient													
0.01		0											
Pressure reducer													
Without pressure reducer				0									
Electrical connection													
9.4 mm special connector for PCB in Type 3965 Solenoid Valve Island, without cable socket							1						
Connector type C according to DIN EN 175301-803, with cable socket, distance between contacts 8 mm							3						
Degree of protection													
IP 54								0					
Supply air													
1.4 to 3.6 bar									0				
Indicator													
Without indicator										0			
Ambient temperature ³⁾													
-25 to +80 °C												1	
-45 to +80 °C												2	
Fail-safe action													
Without fail-safe action													0
SIL ⁴⁾													1

1) EC type examination certificate PTB 98 ATEX 2047

2) Statement of conformity PTB 01 ATEX 2193 X

3) The maximum permissible ambient temperature of the solenoid pilot valve depends on type of protection and temperature class.

4) SIL according to IEC 61508

2 Mounting

Solenoid pilot valves with an interface for direct mounting can be mounted on connecting plates. Solenoid pilot valves with CNOMO adapter plate can be mounted to Type 3756 Booster Valves and valves according to ISO 5999/1.

3 Technical data

Table 1: *General data*

Type 3964		-X1	-X2	-X3	-X8
Design		Solenoid with flapper/nozzle assembly, diaphragm switching element with return spring as booster (optional)			
Degree of protection		IP 20/IP 54 (without/with mounted cable socket)			
Material	Enclosure	Polyamide PA6-3-T, black, polyoxymethylene, green (booster)			
	Adapter plate	Black anodized aluminum			
	Screws	Stainless steel 1.4571			
	Springs	Stainless steel 1.4310			
	Seals	Silicone rubber, Perbunan			
	Diaphragms	Chloroprene rubber 57 Cr 868 (booster, at -25 to +60 °C), silicone rubber (booster, at -40 to +60 °C)			
Ambient temperature		See Electrical data and Pneumatic data			
Mounting orientation		Any desired position			
Approx. weight		50 g, 100 g (with CNOMO adapter plate), 150 g (with CNOMO adapter plate and booster)			

Table 2: *Pneumatic data*

Type 3964		-X1	-X2	-X3	-X8
Supply	Medium	Instrument air, free from corrosive substances			
	Pressure	1.4 to 2.0 bar, 3.0 to 3.6 bar, 3.0 to 8.0 bar			
Output signal	Without booster	≥1.2 bar at 1.4 bar pilot supply, ≥1.8 bar at 2.0 bar pilot supply, ≥2.5 bar at 3.6 bar pilot supply			
	With booster	Same pressure as pilot supply			
Air consumption		≤60 l/h at 1.4 bar pilot supply in neutral position ≤15 l/h at 1.4 bar pilot supply in operating position			

Technical data

Type 3964	-X1	-X2	-X3	-X8
K_{VS} ¹⁾	0.01 (without booster), 0.02 (with booster)			
Ambient temperature ²⁾	-45 to +80 °C, -25 to +60 °C (booster with diaphragm made of chloroprene rubber 57 Cr 868), -45 to +60 °C (booster with diaphragm made of silicone rubber)			
Connection	Connection for direct mounting, optionally with CNOMO adapter plate or connecting plate			

¹⁾ The air flow rate when $p_1 = 2.4$ bar and $p_2 = 1.0$ bar is calculated using the following formula:

$$Q = K_{VS} \times 36.22 \text{ in m}^3/\text{h}.$$

²⁾ The maximum permissible ambient temperature of the solenoid pilot valve depends on type of protection and temperature class.

Table 3: Electric data

Type 3964		-X1	-X2	-X3	-X8
Nominal signal	U_N	6 V DC Max. 27 V ¹⁾	12 V DC Max. 25 V ¹⁾	24 V DC Max. 32 V ¹⁾	24 V AC Max. 36 V ¹⁾
	f_N	-			48 to 62 Hz
Switching point ON	$U_{80^\circ\text{C}}$	≥4.8 V	≥9.6 V	≥18.0 V	19 to 36 V
	$I_{20^\circ\text{C}}$	≥ 1.41 mA	≥ 1.52 mA	≥1.57 mA	≥ 1.9 mA
	$P_{20^\circ\text{C}}$	≥5.47 mW	≥13.05 mW	≥26.71 mW	≥0.04 VA
OFF	$U_{-25^\circ\text{C}}$	≤1.0 V	≤2.4 V	≤4.7 V	≤4.5 V
Impedance	$R_{20^\circ\text{C}}$	2.6 kΩ	5.5 kΩ	10.7 kΩ	Approx. 10 kΩ
Effect of temperature		0.4 %/°C	0.2 %/°C	0.1 %/°C	0.1 %/°C

Type 3964	-X1	-X2	-X3	-X8
Type of protection Ex ia IIC ²⁾ for use in hazardous areas (Zone 1)				
Type 3964	-11	-12	-13	
Maximum values when connected to a certified intrinsically safe circuit				
Output voltage	U_i	Pairs of values U_i/I_i apply to 6, 12, 24 V DC nominal signals:		
Output current	I_i	25 V/150 mA, 27 V/125 mA, 28 V/115 mA, 30 V/100 mA, 32 V/85 mA		
Outer capacitance	C_i	≈0		
Outer inductance	L_i	≈0		
Ambient temperature in temperature class	T6	-20 to +60 °C		
	T5	-20 to +70 °C		
	T4	-20 to +80 °C		
Type of protection Ex nA II ³⁾ for use in hazardous areas (Zone 2)				
Type 3964	-81	-82	-83	
Ambient temperature in temperature class	T6	-45 to +60 °C		
	T5	-45 to +70 °C		
	T4	-45 to +80 °C		
Switching time	≤15 ms			
Effect of temperature	0.4 %/°C	0.2 %/°C	0.12 %/°C	0.15 %/°C
Connection	Connector type C according to EN 175301-803, distance between contacts 8 mm ⁴⁾ or industrial standard type C, distance between contacts 9.4 mm ⁵⁾			

¹⁾ Maximum permissible value at 100 % duty cycle. The maximum permissible value U_i applies to explosion-protected versions.

²⁾ II 2 G Ex ia IIC T6 (Zone 1) according to EC Type Examination Certificate PTB 98 ATEX 2047

³⁾ II 3 G Ex nA II T6 (Zone 2) according to Statement of Conformity PTB 06 ATEX 2193 X

Note: a manufacturer's declaration of use in explosive atmospheres (Zone 22) is available on request.

⁴⁾ The cable socket with seal (option) is included in the scope of delivery.

⁵⁾ The cable socket with seal is not included in the scope of delivery.

4 Safety-related functions

The solenoid pilot valve is actuated by a binary voltage signal. When electrically actuated, pressure is applied to the diaphragm switching element of the solenoid pilot valve, causing the solenoid pilot valve to switch to the operating position. If no voltage signal or no pneumatic supply is applied to the signal input, fail-safe action is triggered and the solenoid pilot valve is switched to the neutral position by a return spring.

4.1 Fail-safe action

Fail-safe action is triggered by the voltage signal or the pneumatic supply. When the voltage signal or the pneumatic supply fail, the pressure applied to the diaphragm switching element drops and the solenoid pilot valve changes to the neutral position. This causes the pneumatic actuator to be vented and the valve to move to its fail-safe position. The fail-safe position depends on how the springs are arranged in the pneumatic actuator (air-to-close or air-to-open).

4.2 Protection against unauthorized changes to the configuration

A change to the configuration cannot affect the safety function nor cause it to be deactivated.

5 Mounting, connection and start-up

Refer to Mounting and Operating Instructions ► EB 3964 for details on how to mount, perform the electric and pneumatic connections as well as start up the solenoid pilot valve. Only use the specified original mounting parts and accessories.

6 Required conditions

WARNING

Risk of malfunction due to incorrect selection or wrong installation and operating conditions.

→ *Only use control valves in safety-instrumented systems if the necessary conditions in the plant are fulfilled. The same applies to the mounted solenoid pilot valve.*

6.1 Selection

- The required transit times of the control valve are observed.
The transit times to be implemented are determined by the process engineering requirements.
- The solenoid pilot valve is suitable for the prevailing ambient temperature.

Versions	Temperature range
Type 3964 (standard)	-45 to +80 °C,
Type 3964 with booster diaphragm made of chloroprene rubber	-25 to +60 °C
Type 3964 with booster diaphragm made of silicone rubber	-45 to +60 °C
The maximum permissible ambient temperature of the solenoid pilot valve depends on type of protection and temperature class.	

→ The temperature limits are observed.

6.2 Mechanical and pneumatic installation

- The solenoid pilot valve is mounted properly as described in the mounting and operating instructions and connected to the air supply.
- The maximum supply pressure does not exceed 3.6 bar.
- The pneumatic air supply meets the instrument air specifications.

Particle size and quantity	Oil content	Pressure dew point
Class 4	Class 3	Class 3
≤ 5 µm and 1000/m ³	≤ 1 mg/m ³	-20 °C or at least 10 K below the lowest ambient temperature to be expected



Tip

We recommend installing a supply pressure regulator/filter upstream of the device. For example, Type 3999-009x Service Unit or Type 3999-0096 Filter Regulator can be used.

- The supply air hoses have a minimum cross section of 4x1 mm (inside diameter x wall thickness).
Select the cross section and length of the line to ensure that the supply pressure at the solenoid pilot valve on supplying air does not fall below the minimum limit of 1.4 bar.

6.3 Electrical installation

- The solenoid pilot valve is connected properly to the electric power supply as described in the mounting and operating instructions.
- Only cables whose outside diameters are suitable for the cable glands are used.

Proof testing

- The electrical cables in Ex i circuits comply with the data that planning was based on.
- The cable glands and enclosure cover screws are fastened tightly to ensure that the degree of protection is met.
- The installation requirements for the applicable explosion protection measures are observed.
- The special conditions specified in the explosion protection certificates are observed.

7 Proof testing

The proof test interval and the extent of testing lie within the operator's responsibility. The operator must draw up a test plan, in which the proof tests and the interval between them are specified. We recommend summarizing the requirements of the proof test in a checklist.

⚠ WARNING

Risk of dangerous failure due to malfunction in the event of emergency (actuator is not vented or the valve does not move to the fail-safe position).

- *Only use devices in safety-instrumented systems that have passed the proof test according to the test plan drawn up by the operator.*

Regularly check the safety-instrumented function of the entire SIS loop. The test intervals are determined, for example on calculating each single SIS loop in a plant (PFD_{avg}).

7.1 Visual inspection to avoid systematic failure

To avoid systematic failure, inspect the solenoid pilot valve regularly. The frequency and the scope of the inspection lie within the operator's responsibility. Take application-specific influences into account, such as:

- Dirt blocking the pneumatic connections
- Corrosion (destruction primarily of metals due to chemical and physical processes)
- Material fatigue
- Aging (damage caused to organic materials, e.g. plastics or elastomers, by exposure to light and heat)

- Chemical attack (organic materials, e.g. plastics or elastomer, which swell, leach out or decompose due to exposure to chemicals)

ⓘ NOTICE

Risk of malfunction due to the use of unauthorized parts.

→ *Only use original parts to replace worn parts.*

7.2 Function testing

Regularly check the safety function according to the test plan drawn up by the operator.

i Note

Record any device faults and e-mail (aftersaleservice@samsongroup.com) them to SAMSON.

- Install the pneumatic connection according to Mounting and Operating Instructions EB 3964.
 - Apply the nominal voltage U_N specified in Table 3 to the solenoid pilot valve.
 - Check whether the valve moves to its end position on demand.
 - De-energize the solenoid pilot valve.
 - Check whether the actuator is fully vented within the demanded time (fail-safe position).
-

💡 Tip

You can connect a pressure gauge to check whether the actuator has completely vented.

- Record the valve transit time and compare it to the time the valve took at start-up and during proof tests.

Maintenance and repair

Proof test

A full stroke test must be performed as the proof test. The following value can be used for Proof Test Coverage to calculate PFD_{avg} :

PTC (Proof Test Coverage) = 95 % for a proof test

8 Maintenance and repair

Only perform the work on the solenoid pilot valve described in ► EB 3964.

! NOTICE

Safety function impaired due to incorrect repair.

→ *Only allow trained staff to perform service and repair work.*

For devices operated in the low demand mode, a useful lifetime of 11 years (plus 1.5 years storage time) is confirmed by TÜV Rheinland® from the date of manufacture while taking into account the specific conditions of use specified in the Safety Manual and the Mounting and Operating Instructions.

The results of the proof test must be assessed and the maintenance scheduled based on it. In particular, after changes (e.g. signs of aging in elastomers, changed switching times or leakage etc.), it is essential that the manufacturer performs maintenance or repair work on the device.

MTC (Maintenance Coverage) > 99 %

9 Safety-related data and certificates

The safety-related data are listed in the following certificate.

Certificate



SIL/PL
Capability

www.tuv.com
ID 0600000000

No.: 968/V 1160.02/21

Product tested	Electromagnetic control, solenoid, booster valves and electrical position feedback	Certificate holder	SAMSON AG Weismüllerstr. 3 60314 Frankfurt / Main Germany
Type designation	3963, 3967, 3964, 3756, 3701, 3968, 3776 (with option solenoid valve as well as safe indication of end positions)		
Codes and standards	IEC 61508 Parts 1-2 and 4-7:2010		
Intended application	Safety Function: Safe venting (and safe indication of end positions) The test items are suitable for use in a safety instrumented system up to SIL 2 (low demand mode). Under consideration of the minimum required hardware fault tolerance HFT = 1 the valves may be used in a redundant architecture up to SIL 3 according to IEC 61508 and IEC 61511-1:2016 + AMD1:2017.		
Specific requirements	The instructions of the associated Installation, Operating and Safety Manual shall be considered.		
Summary of test results see back side of this certificate.			

The issue of this certificate is based upon an evaluation in accordance with the Certification Program CERT FSP1 V1.0:2017 in its actual version, whose results are documented in Report No. 968/V 1160.02/21 dated 2021-09-08. This certificate is valid only for products, which are identical with the product tested.

TÜVRheinland Industrie Service GmbH
Bereich Automation
Funktionale Sicherheit

Köln, 2021-09-13

Certification Body Safety & Security for Automation & Grid

Dipl.-Ing. (FH) Wolf Rückwart

Holder: **SAMSON AG**
 Weismüllerstraße 3
 60314 Frankfurt am Main
 Germany

Product tested: Electromagnetic control, solenoid and booster valves of the types
 3963, 3967, 3964, 3756, 3701, 3968⁴,
 3776 (with option "solenoid valve" as well as "safe indication of end positions")

Results of Assessment

Route of Assessment		2 _H / 1 _S
Type of Sub-system		Type A
Mode of Operation		Low Demand Mode

Safe venting - Type 3701, 3963, 3967, 3776 (with option solenoid valve)

Hardware Fault Tolerance	HFT	0	
Lambda Dangerous Undetected ¹	λ_{DU}	8.02 E-08 / h	80 FIT
Average Probability of Failure on Demand ²	$PFD_{avg}(T_i)$	3.51 E-04	

Safe indication of end positions - Type 3776 (only with inductive proximity switches)

Hardware Fault Tolerance	HFT	0	
Lambda Dangerous Undetected ¹	λ_{DU}	7.35 E-08 / h	74 FIT
Average Probability of Failure on Demand ²	$PFD_{avg}(T_i)$	3.22 E-04	

Safe venting - Type 3756

Hardware Fault Tolerance	HFT	0 (1 as variant, see report)	
Lambda Dangerous Undetected ¹	λ_{DU}	8.38 E-08 / h	84 FIT
Average Probability of Failure on Demand ²	$PFD_{avg}(T_i)$	3.67 E-04	
Average Probability of Failure on Demand ³	$PFD_{avg}(T_i)$	3.69 E-05	

Safe venting - Type 3964 pilot valve

Hardware Fault Tolerance	HFT	0	
Lambda Dangerous Undetected ¹	λ_{DU}	5.12 E-09 / h	5 FIT
Average Probability of Failure on Demand ²	$PFD_{avg}(T_i)$	2.24 E-05	

¹ assumed Diagnostic Coverage DC = 0 %² assumed Proof Test Interval T_i = 1 year³ assumed Proof Test Interval T_i = 1 year and β_{1002} = 10 %⁴ The solenoid valve manifold of type 3968 is a combination of the control valves 3756 and the pilot valves 3964. The failure rates must be determined for each individual application from the given characteristic values of the single components.**Origin of values**

The stated failure rates are the result of an FMEDA with tailored failure rates for the design and manufacturing process.

Furthermore the results have been verified by qualification tests and field-feedback data of the last 5 years.

Failure rates include failures that occur at a random point in time and are due to degradation mechanisms such as ageing.

The stated failure rates do not release the end-user from collecting and evaluating application-specific reliability data.

Systematic Capability

The development and manufacturing process and the functional safety management applied by the manufacturer in the relevant lifecycle phases of the product have been audited and assessed as suitable for the manufacturing of products for use in applications with a maximum Safety Integrity Level of 3 (SC 3).

Periodic Tests and Maintenance

The given values require periodic tests and maintenance as described in the Safety Manual.

The operator is responsible for the consideration of specific external conditions (e.g. ensuring of required quality of media, max. temperature, time of impact), and adequate test cycles.

Revision List
referred to on Certificate No.: 968/V 1160.02/21
Certified Product: Electromagnetic control, solenoid,
booster valves and electrical position feedback



Safety related modules / components

Type Designation	Description	Report-No.:	Certification Status
3963	Solenoid valve	968/V 1160.00/20	Valid
3967	Solenoid valve	968/V 1160.00/20	Valid
3964	Solenoid valve	968/V 1160.00/20	Valid
3756	Solenoid valve	968/V 1160.00/20	Valid
3701	Solenoid valve	968/V 1160.00/20	Valid
3968	Solenoid valve	968/V 1160.00/20	Valid
3776	Limit switch (with option solenoid valve as well as safe indication of end positions)	968/V 1160.00/20	Valid

TP-6033_Revision_List_Template.docx Rev. V1.1

Revision List
referred to on Certificate No.: 968V 1160.02/21
Certified Product: Electromagnetic control, solenoid,
booster valves and electrical position feedback

Manufacturing locations

Type Designation	Description	Report-No.:	Certification Status
SAMSON AG	Weismüllerstraße 3 60314 Frankfurt am Main	968V 1160.00/20	<i>Valid</i>
SAMSON REGULATION S.A.S.	1 rue Jean Corona 69120 Vaulx-en-Velin France	968V 1160.02/21	<i>Valid</i>

Safety Manual

Document No.	Description	Report-No.:	Certification Status
SH_3963.pdf	Safety manual for type 3963	968V 1160.00/20	<i>Valid</i>
SH_3967.pdf	Safety manual for type 3967	968V 1160.00/20	<i>Valid</i>
SH_3701.pdf	Safety manual for type 3701	968V 1160.00/20	<i>Valid</i>
e3756s.de.pdf	Safety manual for type 3756	968V 1160.00/20	<i>Valid</i>
e3964s.de.pdf	Safety manual for type 3964	968V 1160.00/20	<i>Valid</i>
e3776s.de.pdf	Safety manual for type 3776	968V 1160.00/20	<i>Valid</i>
e3968s.de.pdf	Safety manual for type 3968	968V 1160.00/20	<i>Valid</i>

The content of this Revision List has been agreed between Manufacturer and Certification Body.

Revision List
 referred to on Certificate No.: 968V 1160.02/21
**Certified Product: Electromagnetic control, solenoid,
 booster valves and electrical position feedback**



Revision:

Date	Rev.	Description / Changes	Author
2021-09-08	1.0	Initial creation, based on Report-No.: 968V 1160.02/21	JCZ/A-FS

SAMSON AG
 Weismüllerstraße 3
 60314 Frankfurt am Main

TÜV Rheinland Industrie Services GmbH
 Automation - Functional Safety (A-FS)
 Am Grauen Stein
 51105 Köln / Germany

SH 3964 EN



SAMSON AKTIENGESELLSCHAFT
Weismüllerstraße 3 · 60314 Frankfurt am Main, Germany
Phone: +49 69 4009-0 · Fax: +49 69 4009-1507
samson@samsongroup.com · www.samsongroup.com