

T 8365 EN Type 4746 Electric or Pneumatic Limit Switch



Application

Limit switches with inductive, electric or pneumatic contacts for attachment to pneumatic or electric control valves, to Type 4763 Electropneumatic Positioners or Type 4765 Pneumatic Positioners
Rated travels from 7.5 to 180 mm

The limit switches supply a signal when the valve travel exceeds or falls below the adjusted limit value. This signal is suitable for initiating visual or audible alarms as well as actuating valves or other switching units. Moreover, the limit switches can be connected to central control or alarm systems.

Optionally available with:

- Two inductive limit contacts
- Two electric limit contacts or
- Two pneumatic limit contacts

The limit contacts can be overridden. They can either be used as NO or NC contacts. The metal tag is outside the inductive field for the NO contact and inside the inductive field for the NC contact.

Versions also available

- For use in hazardous areas in type of protection intrinsically safe II 2G Ex ia IIC T6 or II 3G Ex nA II T6 for Zone 2
- Conforming to Canadian or US explosion protection approvals

Special features

- Excellent switching accuracy
- Limit contacts do not influence each other
- Hysteresis (dead band) dependent on effective lever length

Attachment to control valves with cast yokes or rod-type yokes according to IEC 60534-6 as well as to Type 4763 Electropneumatic Positioners or Type 4765 Pneumatic Positioners

Versions

Type 4746-x2 (Fig. 1) · Inductive limit switch with non-contact limit pick-up using metal tags and proximity switches (according to EN 60947-5-6)

On request with proximity switches with integral output amplifier designed as three-wire switch (no transistor relay required)

Type 4746-x3 · Electric limit switch with electric double-throw switch with friction snap-action contacts



Fig. 1: Type 4746-x Inductive Limit Switch

Type 4746-04 · Pneumatic limit switch with pneumatic limit contacts and downstream pneumatic microswitches. Supply air 1.4 bar (20 psi), output 0 or 1.4 bar (20 psi)

Versions for hazardous areas

Type 4746-1 · Limit switch with contact circuit in type of protection intrinsically safe  II 2G Ex ia IIC T6

Type 4746-8 · Limit switch in type of protection non-sparking  II 3G Ex nA II T6 for Zone 2

Versions with Canadian or US explosion protection certification are available. Refer to the summary of explosion protection certificates.

Special version on request: Housing for limit contacts, see page 6

For more information on the selection and application of positioners and limit switches, refer to Information Sheet

▶ T 8350

Principle of operation (Fig. 2 to Fig. 4)

The valve travel is transmitted either directly to the pin (1.1) and lever (1) of the limit switch by the plate (20) or by a coupling pin when a positioner is attached. The linear travel is converted into a rotary motion by the shaft (2).

All limit switches have a small hysteresis which depends on the lever length L (see Technical data). Due to this, unnecessary contact changeover is avoided and signal processing is facilitated even when the valve stem position is within the limit signal range.

Type 4746-x2 Inductive Limit Switch (Fig. 2)

In this version, the shaft (2) carries two switch cases (3) with adjustable metal tags (4.1) for non-contact activation of the proximity switches (5). When the tag is located in the inductive field of the switch, the switch assumes a high resistance. When it moves outside the field, the switch assumes a low resistance. The switching function and switching point are continuously adjustable using the adjustment screw (3.1).

For operation of the standard inductive limit switches (two-wire according to EN 60947-5-6), appropriate transistor relays must be connected to the output circuit. The three-wire version comprising the Type SB3,5-E2 proximity switch includes an integrated output amplifier and does not require a transistor relay.

Type 4746-x3 Electric Limit Switch (Fig. 3)

In this version, the shaft (2) carries two switch cases (3) with adjustable cam disks (4.2). Each cam disk activates an electric double-throw switch (7) over the roller (6.1), which is attached to the switch lever (6). The switching function and switching point are continuously adjustable using the adjustment screw (3.1).

Type 4746-04 Pneumatic Limit Switch (Fig. 4)

In this version, the shaft (2) carries two switch cases (3) with adjustable cam disks (4.2). Inside the switch (8), each cam disk activates a nozzle-flapper system whose cascade pressure (p_{k1} or p_{k2}) is used to reverse the pneumatic microswitch (9).

Whenever the cam disk (4.2) activates the switch lever (6) over the roller (6.1), the nozzle in the pneumatic switch (8) is opened and the supply air p_z is switched from the microswitch (9) through to port A_1 or A_2 . This means that input 5 is connected to output 3 and $p_{a1} = p_z$ or $p_{a2} = p_z$. As soon as the cam releases the switch lever (6), the nozzle (8.1) in the pneumatic switch (8) is closed. The microswitch changes over and the available air supply is shut off; i.e. $p_{a1} = 0$ or $p_{a2} = 0$. The switching function and the switching point are continuously adjustable at the adjustment screw (3.1)

Travel range

The limit switch requires different levers (1) depending on the travel range of the valve used:

- Lever I (149 mm) for travels up to max. 60 mm
- Lever II (202 mm) for travels exceeding 60 mm to max. 180 mm

Whenever the limit switch is attached to positioners, a special lever, regardless of the valve travel, needs to be used.

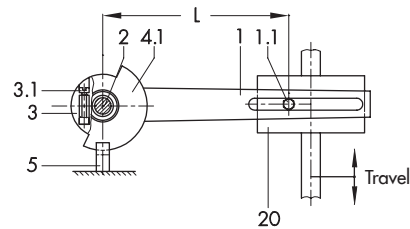

Fig. 2: Functional diagram of inductive limit switch

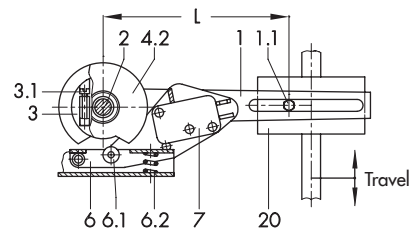
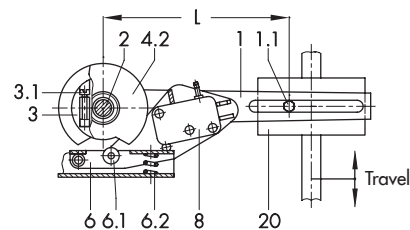
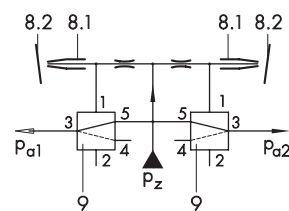

Fig. 3: Functional diagram of electric limit switch



4.1 · Functional diagram of mechanical switching mechanism



4.2 · Functional diagram of switching function

Fig. 4: Pneumatic limit switch

Legend for Fig. 2 to Fig. 4:

1 Lever for valve travel	6.1 Roller
1.1 Pin	6.2 Spring
2 Shaft	7 Electric contact
3 Switch case	8 Pneumatic contact
3.1 Adjustment screw	8.1 Nozzle (in contact)
4.1 Metal tag	8.2 Flapper (in contact)
4.2 Cam disk	9 Pneumatic microswitch
5 Proximity switch of control	20 Plate attached either to actuator stem or plug stem
6 Switch lever	

Table 1: Technical data

Inductive Limit Switch	Type 4746-x2			Type 4746-0281
Control circuit	Switching amplifier according to EN 60947-5-6			Three-wire switch Operating voltage 10 to 30 V
Proximity switch	SC3,5-N0-YE ²⁾	SJ3,5-SN	SJ3,5-S1N	SB3,5-E2
Permissible ambient temperature ¹⁾	-20 to 70 °C	-20 to 100 °C	-20 to 100 °C	-20 to 70 °C
With metal cable gland	-40 to 70 °C	-50 to 100 °C	-40 to 100 °C	-25 to 70 °C
Switching function	NC contact	NC contact	NO contact	NO contact
Electrical connections	One M20x1.5 cable gland for 5.5 to 13 mm clamping range Screw terminals for 0.2 to 2.5 mm ² wire cross-section			
Degree of protection	IP 65			
Weight	Approx. 0.7 kg			
Type 4746-x3 Electric Limit Switch · Specifications apply to silver and gold-plated contacts				
Switching element	Electric limit switch: changeover contact/SPDT (single-pole/double-throw type)			
Permissible load	AC voltage: 220 V/6.9 A DC voltage: 220 V/0.25 A · 20 V/6.9 A			
Permissible ambient temperature ¹⁾	-20 to 85 °C			
With metal cable gland	-40 to 85 °C			
Electrical connections	One M20x1.5 cable gland for 5.5 to 13 mm clamping range Screw terminals for 0.2 to 2.5 mm ² wire cross-section			
Degree of protection	IP 65			
Weight	Approx. 0.7 kg			
Type 4746-04 Pneumatic Limit Switch				
Switching element	Pneumatic limit contact with downstream pneumatic microswitch			
Supply air	1.4 bar (20 psi), can be briefly overloaded up to 4 bar (60 psi)			
Air consumption	0.04 m _n ³ /h			
Output	0 or 1.4 bar (20 psi)			
Air capacity	One switch closed: 0.7 m _n ³ /h Two switches closed: 1.0 m _n ³ /h			
Permissible ambient temperature	-20 to 60 °C			
Degree of protection	IP 54			
Weight	Approx. 0.75 kg			
Materials				
Housing and cover	Powder-coated aluminum			
Lever and shaft	1.4571			
Cable gland	M20x1.5, black polyamide			
Travel range				
Attachment according to IEC 60534-6	Lever I: 7.5 to 60 mm · Lever II: 60 to 180 mm			
Attachment to Type 4763 and Type 4765 Positioner	Travel same as positioner			
Compliance	CE · EAC			

¹⁾ Observe the limits concerning permissible ambient temperatures specified in the EC type examination certificate.

²⁾ Models manufactured until 2006 with SJ3,5-N proximity switch.

Table 2: Technical data for Type 4746-1 with type of protection Ex ia (ATEX)

Maximum values for connection to certified intrinsically safe circuits

Limit Switch	Type 4746-12		Type 4746-13
	Inductive		Electric
U _i	16 V	16 V	45 V
I _i	52 mA	25 mA	–
P _i	169 mW	64 mW	2 W
C _i - effective inner capacitance	60 nF	50 nF	Negligibly small
L _i - effective internal inductance	160 µH	250 µH	
Temperature classes	Ambient temperature range according to EC type examination certificate (technical data specified Table 1 additionally apply)		
T4	-45 to +89 °C	-45 to +100 °C	-45 to +80 °C
T5	-45 to +60 °C	-45 to +81 °C	-45 to +70 °C
T6	-45 to +45 °C	-45 to +66 °C	-45 to +60 °C

Table 3: Hysteresis (dead band)

Type 4746	-x2	-x3	-04
Lever length L	Hysteresis		
50 mm	0.15 (0.25 ¹⁾) mm	0.6 mm	0.75 mm
120 mm	0.30 (0.55 ¹⁾) mm	1.0 mm	1.5 mm

¹⁾ Special version

Ordering text

Types 4746-x2/-x3/-04 Limit Switch
 Operating as normally open/normally closed contact
 To indicate valve OPEN/valve CLOSED
 Optionally, special version

Accessories

Mounting parts for attachment to
 Type 4763/4765 Positioner
 Valve with cast yoke with lever I or II
 Valve with rod-type yoke with lever I or II

Adapter 1/2 NPT for electrical connections

Dimensions in mm

Type 4746-x2, -x3 · Air connection for separate air supply
 Tapped hole G 1/8

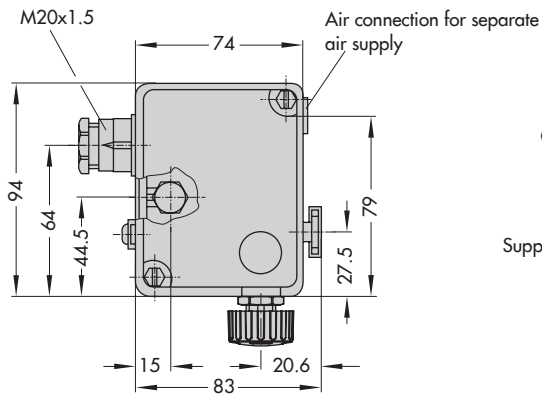

Type 4746-04 · Air connections, tapped hole G 1/8
 or 1/8 NPT

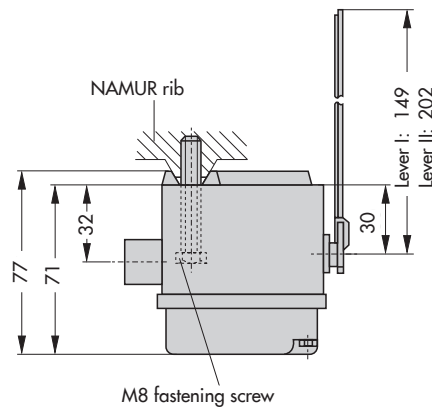
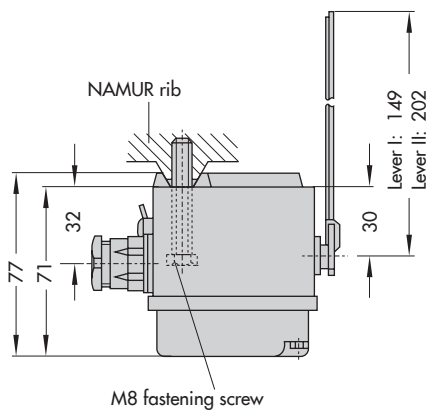
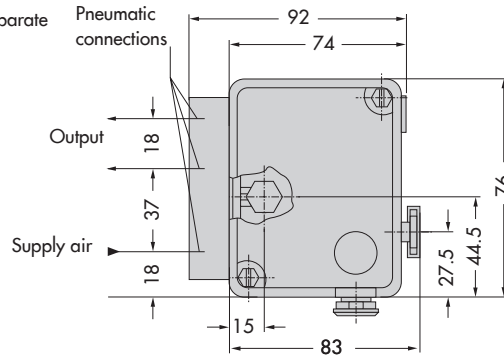

The dimensions required for attachment to Type 4765 Pneumatic Positioner and Type 4763 Electropneumatic Positioners can be found in Mounting and Operating Instructions ► EB 8365.

Electrical connection

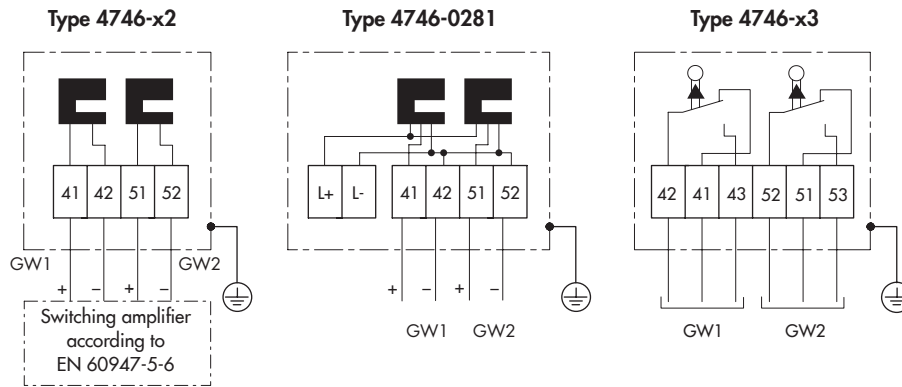

Table 4: Summary of explosion protection certificates

Type	Certification		Type of protection
4746-1		Number	RU C-DE.HA65.B.00615/20
		Date	2020-06-08
4746-1		Number	13-KB4BO-0038
		Date	2013-01-31
4746		Number	ZETC/24/2018
		Date	2018-04-27
4746-12		Number	2021322307003671
		Date	2021-01-26
4746-12		Number	A/P/HQ/MH/104/1793
		Date	2016-11-12
4746-1x		Number	PTB 98 ATEX 2114
		Date	2020-02-04
4746-3		Number	1607226
		Date	2005-09-16
4746-32 4746-33		Number	3020228
		Date	2015-10-12
4746-8		Number	2021322307003671
		Date	2021-01-26
4746-8		Number	ZETC/24/2018
		Date	2018-04-27
4746-82		Number	PTB 02 ATEX 2012 X
		Date	2002-04-05
4746-83		Number	PTB 02 ATEX 2012 X
		Date	2002-04-05

Article code

Electric or Pneumatic Limit Switch	Type 4746-	x	x	x	x	x	x	x	0	x	x	x	x
Explosion protection													
Without	0												
1Ex ia IIC T6...T4 Gb X, ATEX	1												
CSA/FM intrinsically safe/non incandive	3												
I 3G Ex nA II T6, ATEX	8												
Version													
Inductive		2				1/2							
Electric		3				2							
Pneumatic	0	4				2							
Contacts													
Proximity switch SC3,5-NO-YE (NAMUR NC contact) ¹⁾		2	0	0		1	0						
Proximity switch SJ3,5-SN (NAMUR NC contact in safety circuit)		2	1	0		1	0						
Proximity switch SJ3,5-S1N (NAMUR NO contact in safety circuit)		2	1	1		1	0						
SAIA - electric microswitch XGK 3 (silver contacts)		3	2	0	2	1	0						
SAIA - electric microswitch XGK3-81 (gold-plated contacts)		3	2	1	2	1	0						
Pneumatic microswitch	0	4	4	0	2	0							
Proximity switch SB3,5-E2 (three-wire switch), NO contact	0	2	8	1	2	1	0						
Switching elements													
With one switching element						1							
With two switching elements						2							
Electrical connection													
Without	0	4	4	0		0							
Plastic cable gland M20 x 1.5, black						1	0						
Pneumatic connections													
Without							0						
ISO 221/1-G 1/8	0	4	4	0		0	1						
1/8-27 NPT	0	4	4	0		0	2						
Special versions													
Without										0	0	0	
Ex ia IIC T4~T6 Gb, CCC Ex	1	2	2							0	0	9	
Ex ia IIC T4~T6 Gb; Ex ic IIC T4~T6 Gc; Ex nA IIC T4~T6 Gc, CCC Ex	8	2	2							0	1	0	
1Ex ia IIC T6...T4 Gb X, EAC	1	2/3								0	1	3	
Paint compatibility													
Without													0
Free of substances that can impair paint adhesion													1

¹⁾ Type 4746-3200 only with FM certificate

Special version on request:

Housing with electric terminals, ready for installing one or two inductive cylinder-shaped limit contacts with M8 or M12 male thread

