

T 8497 EN

TROVIS 3797 Smart Positioner (PROFINET®)



Application

Single-acting or double-acting positioner for attachment to pneumatic control valves. Self-calibrating, automatic adaptation to valve and actuator.

Valve travel 3.6 to 300 mm

Opening angle 24 to 170°

The positioner ensures a predetermined assignment of the valve position to the input signal. It compares the input signal received from a control system to the travel or rotational angle of the control valve and issues a corresponding output signal pressure (output variable).

Special features

- High air capacity
- Modular design: easy retrofitting or exchange of pneumatic or option modules
- Simple attachment to all common linear and rotary actuators:
 - SAMSON direct attachment
 - NAMUR rib
 - Attachment to rod-type yokes according to IEC 60534-6-1
 - Attachment according to VDI/VDE 3847
 - Rotary actuator attachment according to VDI/VDE 3845
- Non-contact position sensing
- Plain-text display with NAMUR Recommendation NE 107 states and messages on the device
- Integrated diagnostic functions
- Simple one-knob, menu-driven operation
- LCD easy to read in any mounting position thanks to selectable reading direction
- Configurable with a computer over the SSP interface using the TROVIS-VIEW software
- Variable, automatic start-up with four different initialization modes
- Sub (substitution) initialization mode allows the positioner to be started up in case of emergency whilst the plant is running without having to change the valve position.
- All parameters saved in non-volatile EEPROM
- Two-wire system with a small electrical load of 495 Ω

- Adjustable tight-closing function
- Continuous zero monitoring
- Integrated temperature sensor and operating hours counter
- Self-diagnostics, messages as condensed state conforming to NAMUR Recommendation NE 107
- Integrated EXPERTplus diagnostics for control valves (► T 8389-4)
- Pressure sensors to monitor the supply air and signal pressure
- Air capacity adjustable by software



Fig. 1: TROVIS 3797 Electropneumatic Positioner

Design and principle of operation

The TROVIS 3797 Electropneumatic Positioner is mounted on pneumatic control valves and used to assign the valve position (controlled variable x) to the control signal (set point w). The positioner compares the electric control signal issued by a control system using PROFINET over APL to the travel or opening angle of the control valve and issues a signal pressure for the pneumatic actuator. The positioner mainly consists of a non-contact travel sensor system (2), pneumatics and the electronics with the microcontroller (4). The output of the standard version is either single or double acting; which means both the Output 138 and Output 238 can provide the output variable and route the signal pressure to the actuator.

The positioner can be configured to meet requirements of an application by adding a maximum of two pneumatic modules (A, B). The pneumatic modules mainly consist of a microcontroller, which operates an i/p converter with downstream spool valve. Depending on the actuator used, an output of the positioner can be sealed to achieve a single-acting function.

The valve position is transmitted either as an angle of rotation or linear travel to the pick-up lever, from there to the travel sensor (2) and forwarded to the microcontroller (4). The PID algorithm in the microcontroller compares the valve position measured by the travel sensor (2) to the control signal issued by the control system. In case of a set point deviation, the

pneumatic module (A, B) causes the actuator (1) to be either vented or supplied with air. As a result, the closure member of the valve (e.g. plug) is moved to the position determined by the set point.

The pneumatic module is supplied with air. The flow rate of the module's output can be restricted by software.

The positioner is operated by a rotary pushbutton (8) for menu navigation on the plain-text display (7).

The extended EXPERTplus diagnostics are integrated into the positioner. They provide information on the control valve and positioner and generate diagnostic and status messages, which allow faults to be pinpointed quickly.

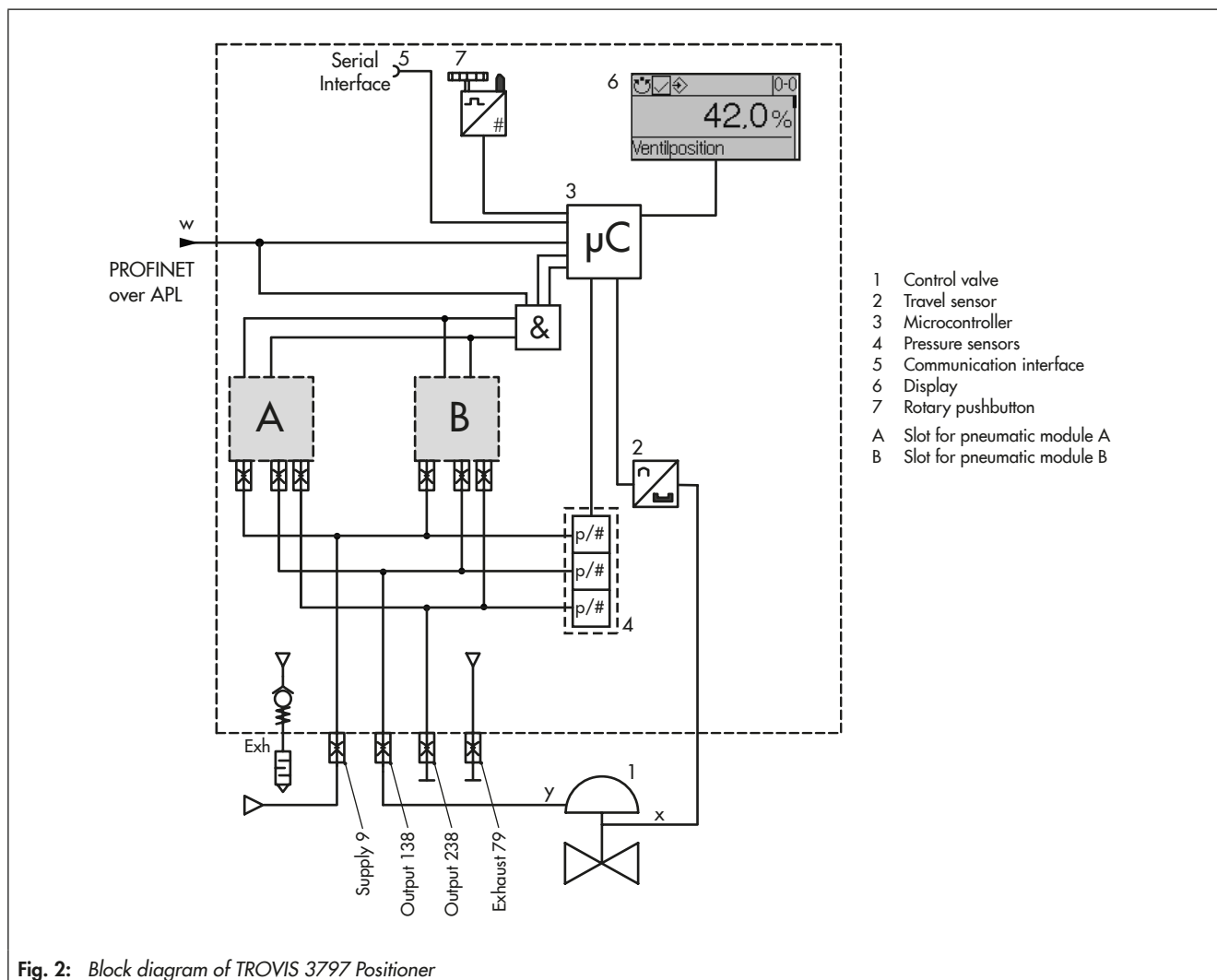

Fig. 2: Block diagram of TROVIS 3797 Positioner

Technical data · TROVIS 3797 Positioner

Travel	
Adjustable travel for	Direct attachment to Type 3277: 3.6 to 30 mm Attachment according to IEC 60534-6 (NAMUR): 5 to 300 mm Attachment according to VDI/VDE 3847-1: 5 to 300 mm Attachment according to VDI/VDE 3845 and VDI/VDE 3847-2: 24 to 100° (170° ¹⁾)
Ethernet APL	
Standard	10BASE-T1L according to IEEE 802.3cg
Transmission rate	10 Mbit/s
Max. connection length	1000 m · Connection at the field switch: spur cable 200 m
Max. power supply values	17.5 V · 380 mA · 5.32 W
Connection	Two-wire, reverse polarity protection 2-WISE according to EN 60079-11 and TS IEC 60079-47
Communication	PROFINET over Ethernet APL
Local	SAMSON SSP interface and serial interface adapter or SSP over APL (software requirements: TROVIS-VIEW with database module 3797)
Supply air	
Supply air	2.5 to 10 bar/30 to 150 psi
Air quality acc. to ISO 8573-1	Max. particle size and density: Class 4 Oil content: Class 3 Pressure dew point: Class 3 or at least 10 K below the lowest ambient temperature to be expected
Signal pressure (output)	0 bar up to supply pressure
Hysteresis	≤0.3 %
Sensitivity	≤0.1 %, adjustable by software
Start-up time	After interrupted operation < 300 ms: 100 ms After interrupted operation > 300 ms: ≤2 s
Transit time	Up to 10000 s separately adjustable for exhaust and supply by software
Direction of action	Reversible
Air consumption ²⁾	≤300 l _n /h with 6 bar supply pressure, depending on module
Air output capacity (when Δp = 6 bar)	
Actuator (supply)	32 m _n ³ /h with one pneumatic module (K _{V max} (20 °C) = 0.34)
	60 m _n ³ /h with two pneumatic modules of the same sort (K _{V max} (20 °C) = 0.64)
Actuator (exhaust)	37 m _n ³ /h with one pneumatic module (K _{V max} (20 °C) = 0.40)
	70 m _n ³ /h with two pneumatic modules of the same sort (K _{V max} (20 °C) = 0.75)
Environmental conditions and permissible temperatures	
Permissible environmental conditions according to EN 60721-3	
Storage	1K6 (relative humidity ≤95 %)
Transport	2K4
Operation	4K4 -40 to +85 °C (versions with metal cable glands) Ex version: -40 to 80 °C (with metal cable gland). The limits in the test certificate additionally apply.
Resistance to vibration	
Vibrations (sinusoidal)	According to DIN EN 60068-2-6: 0.15 mm, 10 to 60 Hz; 20 m/s ² , 60 to 500 Hz per axis 0.75 mm, 10 to 60 Hz; 100 m/s ² , 60 to 500 Hz per axis
Bumps (half sine)	According to DIN EN 60068-2-29: 150 m/s ² , 6 ms; 4000 bumps per axis
Noise	According to DIN EN 60068-2-64: 10 to 200 Hz: 1 (m/s ²) ² /Hz 200 to 500 Hz: 0.3 (m/s ²) ² /Hz 4 h/axis
Recommended continuous duty	≤20 m/s ²

Influences	
Temperature	≤0.15 %/10 K
Supply air	None
Requirements	
EMC	Complying with EN 61000-6-2, EN 61000-6-3, EN 61326-1 and NAMUR Recommendation NE 21
Degree of protection	IP 66
Conformity	CE · ENEC
Electrical connections	
Cable glands	Max. four, M20x1.5
Terminals	Screw terminals for 0.2 to 2.5 mm ² wire cross-section
Explosion protection	
	Refer to Table 3
Materials	
Housing and cover	Die-cast aluminum EN AC-ALSi12 (Fe) (EN AC-44300) acc. to DIN EN 1706, chromate and powder coating
Window	Makrolon® 2807
Cable glands	Nickel-plated brass, stainless steel 1.4305
Other external parts	Stainless steel 1.4571 and 1.4404 (316 L)
Weight	
	1.4 to 1.6 kg (depending on version)

1) On request

2) Based on temperature range -40 to +80 °C

Table 1: Pressure sensors

Pressure sensors	
Pressure range	0 to 10 bar

Table 2: Summary of explosion protection certificates for TROVIS 3797 Positioner

TROVIS 3797	Certification		Type of protection
-110	ATEX	Number	II 2G Ex ia IIC T4 Gb
		Date	
-111	IECEX	Number	Ex ia IIC T4 Gb
		Date	

Mounting the positioner

The positioner can be attached directly to the Type 3277 Actuator (240 to 750 cm²) over a connection block. In actuators with "actuator stem extends" fail-safe action, the signal pressure is routed over an internal hole in the actuator yoke to the actuator. In actuators with "actuator stem retracts" fail-safe action, the signal pressure is routed to the actuator over ready-made external piping.

Using the appropriate bracket, the positioner can also be attached according to IEC 60534-6-1 (NAMUR recommendation). The positioner can be mounted on either side of the control valve.

A pair of universal brackets is used for the attachment to Type 3278 Rotary Actuators or other rotary actuators according to VDI/VDE 3845. The rotary motion of the actuator is transferred to the positioner over a coupling wheel with travel indication.

A special version of the positioner allows it to be attached according to VDI/VDE 3847. This type of attachment allows the positioner to be replaced quickly while the process is running by blocking the air in the actuator. The positioner can be attached directly to the Type 3277 Actuator using an adapter bracket or adapter block. Alternatively, it can be attached to the NAMUR rib of a control valve using an additional NAMUR connection block.

Version

The TROVIS 3797 Electropneumatic Positioner can be used as a single or double-acting positioner, depending on the combination of the available pneumatic modules.

- **TROVIS 3797** · Electropneumatic positioner for control valves, PROFINET® communication, on-site operation, local communication with SSP interface, EXPERTplus diagnostics, pressure sensors to monitor the supply air and signal pressure

Table 3: Available pneumatic modules

Article code	Function
P3799-0000	Dummy module (seals the slot connections and must be used when only one pneumatic module is installed)
P3799-0001	Output 138 and Output 238 module (single and double acting)

Electrical connection

The positioner is powered over the Ethernet-APL connection (see Fig. 4). No other current or voltage source is required.

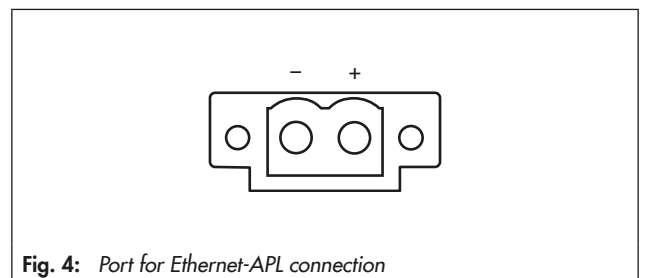
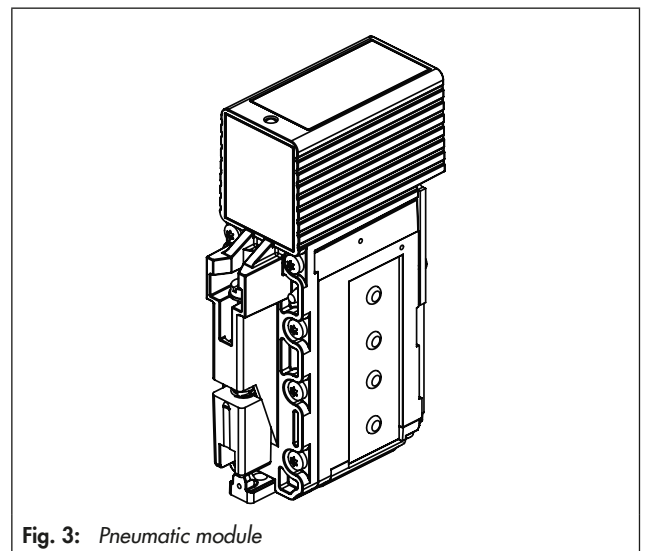

Operation

The positioner is operated using one proven, user-friendly rotary pushbutton: the various menu levels, parameters and values are selected by turning the button. By pressing the button, the required setting is activated. All parameters can be checked and changed on site.

All values are displayed on the plain-text display. The reading direction of the display can be rotated by 180°.

The initialization key activates initialization which is started according to the ready adjusted parameters (autotune). After initialization is completed, the positioner immediately starts closed-loop operation.

To configure the positioner with SAMSON's TROVIS-VIEW software, the positioner is equipped with an additional digital interface to be connected to the USB interface of a computer using an adapter.

Additionally, all parameters of the TROVIS 3797 Positioner can be accessed using PROFINET® communication.

Dimensions in mm

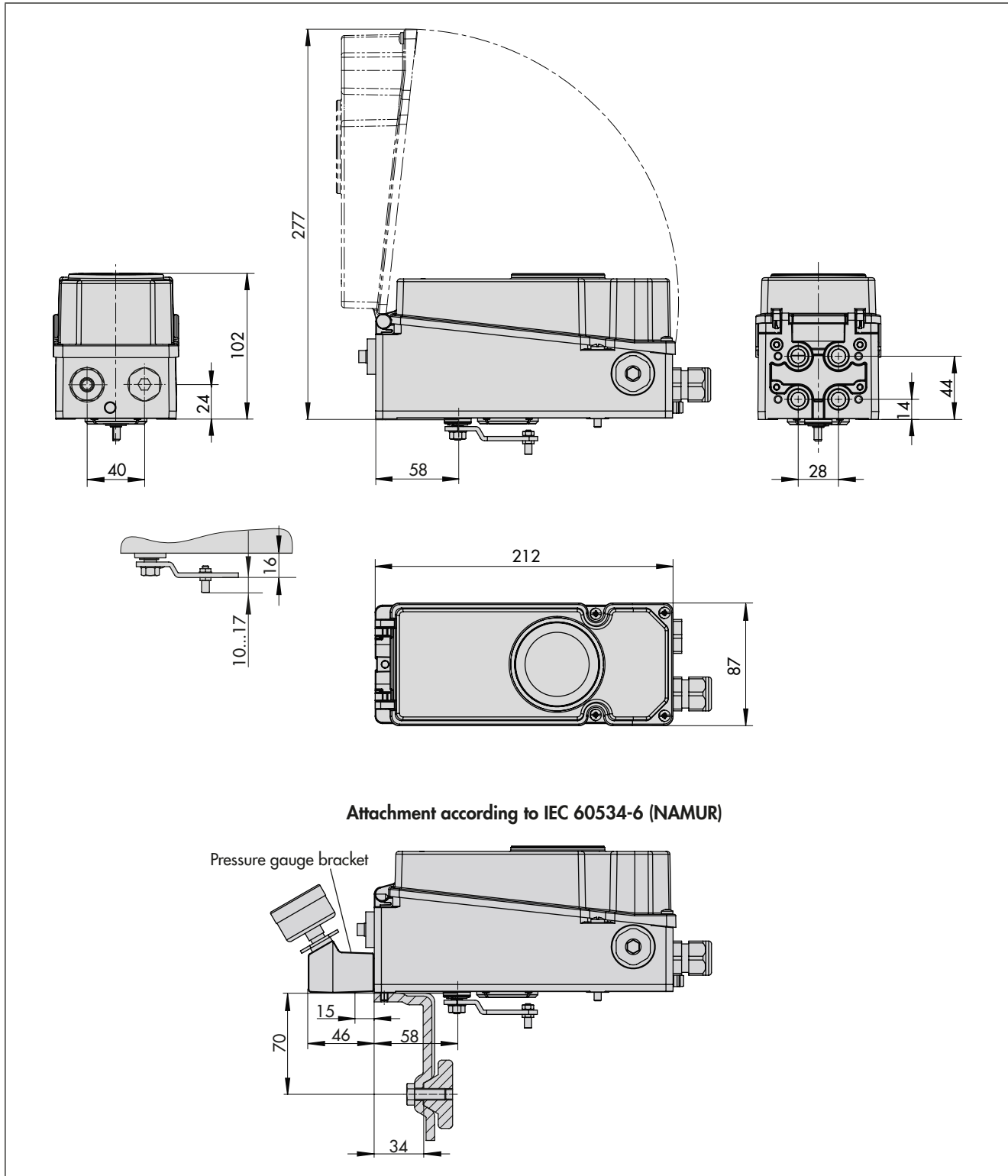

Attachment according to VDI/
VDE 3847 onto Type 3277 Actuator

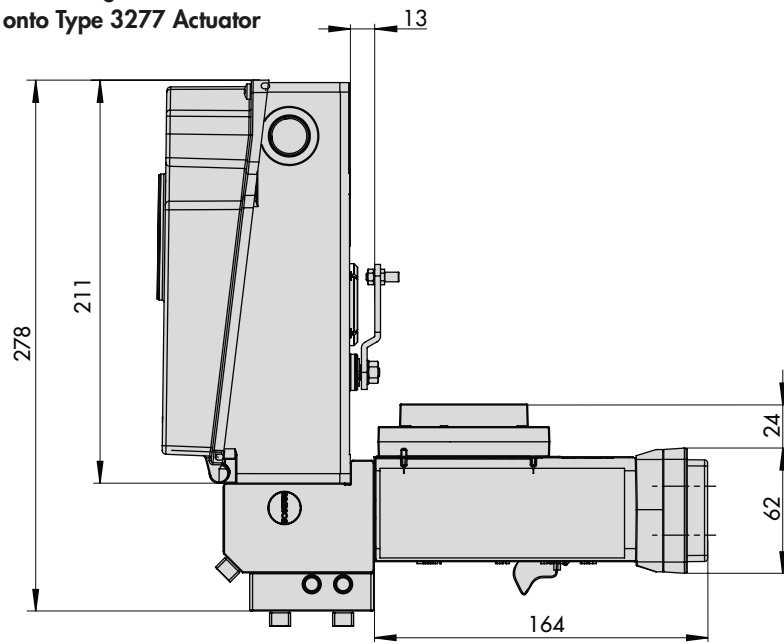

Attachment according to VDI/
VDE 3847 to a NAMUR rib

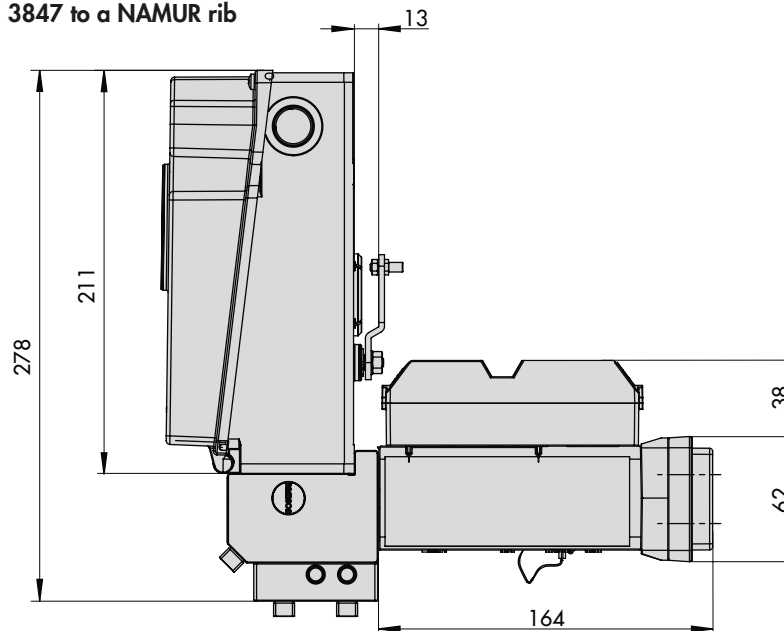

Attachment to rotary actuators according to VDI/VDE 3845

Fixing level 1, AA1 to AA4 size

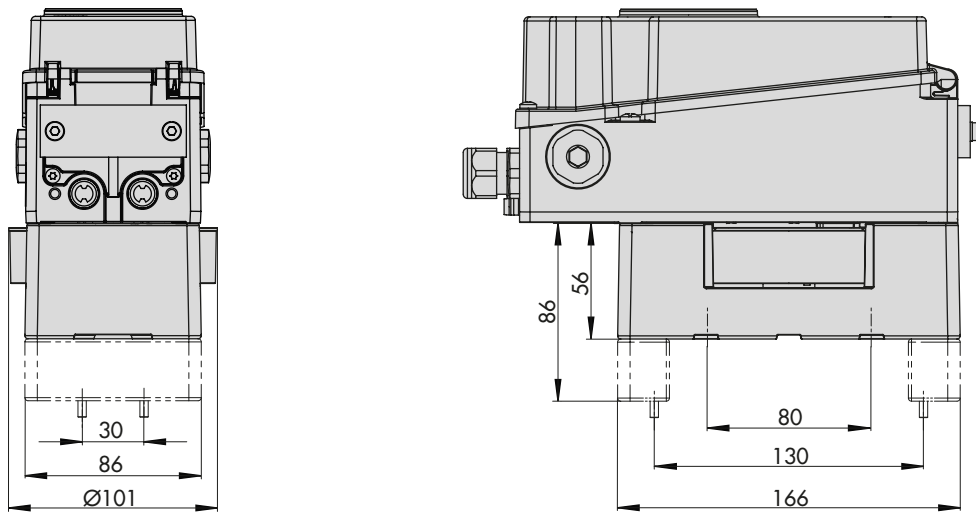

Lever

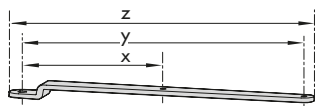

Lever	x	y	z
M	25 mm	50 mm	66 mm
L	70 mm	100 mm	116 mm
XL	100 mm	200 mm	216 mm
XXL	200 mm	300 mm	316 mm

Fixing levels according to VDI/VDE 3845 (September 2010)

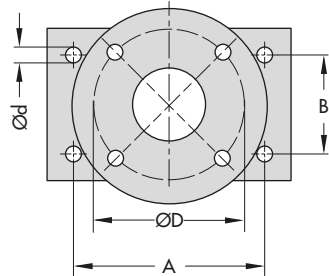
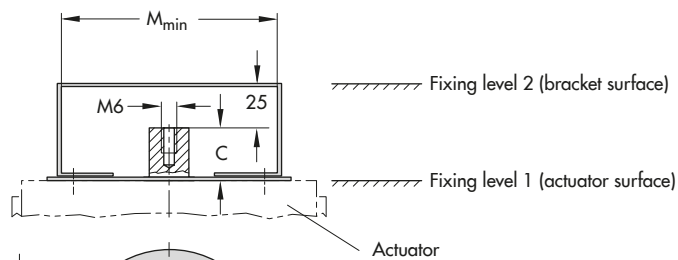

Dimensions in mm

Size	A	B	C	Ød	M _{min}	D ¹⁾
AA0	50	25	15	5.5 for M5	66	50
AA1	80	30	20	5.5 for M5	96	50
AA2	80	30	30	5.5 for M5	96	50
AA3	130	30	30	5.5 for M5	146	50
AA4	130	30	50	5.5 for M5	146	50
AA5	200	50	80	6.5 for M6	220	50

¹⁾ Flange type F05 acc. to DIN EN ISO 5211

Pressure gauge bracket, two pressure gauges

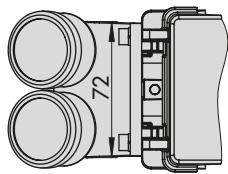
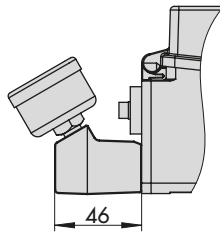

Pressure gauge bracket, three pressure gauges

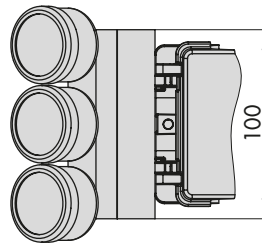
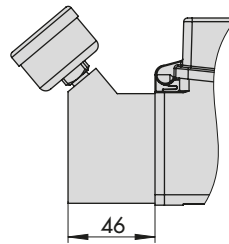

Connecting plate

